

Informational differences and entrepreneurial networking among small and medium enterprises in Kampala, Uganda: The mediating role of ecologies of innovation

Samuel Mayanja, Joseph M. Ntayi, J.C. Munene, Waswa Balunywa, Arthur Sserwanga & James R.K. Kagaari |

To cite this article: Samuel Mayanja, Joseph M. Ntayi, J.C. Munene, Waswa Balunywa, Arthur Sserwanga & James R.K. Kagaari | (2019) Informational differences and entrepreneurial networking among small and medium enterprises in Kampala, Uganda: The mediating role of ecologies of innovation, Cogent Business & Management, 6:1, 1617020, DOI: [10.1080/23311975.2019.1617020](https://doi.org/10.1080/23311975.2019.1617020)

To link to this article: <https://doi.org/10.1080/23311975.2019.1617020>



© 2019 The Author(s). This open access article is distributed under a Creative Commons Attribution (CC-BY) 4.0 license.



Published online: 31 May 2019.



[Submit your article to this journal](#)



Article views: 815



[View related articles](#)



[View Crossmark data](#)



Citing articles: 2 [View citing articles](#)



Received: 14 December 2018
Accepted: 04 May 2019
First Published: 29 May 2019

*Corresponding author: Samuel Mayanja, Business and Management, Cavendish University Uganda, Uganda
E-mail: smayanja@cavendish.ac.ug

Reviewing editor:
Sebastian Aparicio, Business,
Universitat Autònoma de Barcelona,
Spain

Additional information is available at
the end of the article

MANAGEMENT | RESEARCH ARTICLE

Informational differences and entrepreneurial networking among small and medium enterprises in Kampala, Uganda: The mediating role of ecologies of innovation

Samuel Mayanja^{1*}, Joseph M. Ntayi², J.C. Munene³, Waswa Balunywa⁴, Arthur Sserwanga⁴ and James R.K. Kagaari⁵

Abstract: This paper examines the mediating role of ecologies of innovation in the relationship between informational differences and entrepreneurial networking among small and medium enterprises (SMEs) in Kampala, Uganda. To empirically validate the conceptual model and test the hypothesised relationships, the authors collected data from a sample of 228 SMEs in Kampala district, Uganda purposefully selected for this study. A cross-sectional survey design was adopted, and data were analysed using SPSS/20 and AMOS version 23. The findings exhibit a full mediation of ecologies of innovation in the relationship between informational differences and entrepreneurial networking among SMEs. Besides, informational differences and



Samuel Mayanja

ABOUT THE AUTHORS

Samuel Mayanja is currently undertaking post-graduate studies leading to the award of a PhD degree at Makerere University. He is Director School of Working Adults at Cavendish University Uganda. His research interests are in entrepreneurship, self-employment, rural finance, business succession planning and generational transfer and project management. Email: ssekajjasam@gmail.com

Joseph M. Ntayi, PhD, is a professor of Procurement and Logistics Management at Makerere University Business School, Kampala, Uganda. His research interests are in logistics, entrepreneurship, public procurement, business ethics, industrial marketing, purchasing and supply chain management.

J. C. Munene, PhD, is a professor of Psychology and Director of the PhD programmes at Makerere University Business School, Kampala, Uganda. His research interests are in industrial and organisational psychology.

Balunywa Waswa, PhD, is a professor of entrepreneurship and Principal of Makerere University Business School. His research interest is in innovations, repeat entrepreneurs and small business start-ups.

James R.K. Kagaari, PhD, is an associate professor of industrial psychology. He lectures at Kyambogo University and Makerere University Business School.

PUBLIC INTEREST STATEMENT

Uganda is rich in social networks that provide tangible and intangible resources that are useful for SMEs to start and grow by overcoming the liability of smallness. Although Uganda has strong and weak ties, with high entrepreneurial index in the world, 50% of SMEs do not celebrate their third birthday. Although efforts have been made to train owners/managers of SMEs on how to access resources using entrepreneurial networks, they are still struggling to manage informational differences and ecologies of innovation that promote interactions among employees to access resources. Thus, in public interest, this study attempts to promote entrepreneurial networking through informational differences and ecologies of innovation. The paper makes significant contribution to existing body of literature by showing employees how they should attach meaning to information based on employees' background and perceptions with support of management. SMEs need enabling environment to promote creativity and innovation, access resources from entrepreneurial networks to attain competitiveness.

entrepreneurial networking are insignificantly related. There were, however, some limitations: as the study was cross-sectional in nature, it was difficult to trace the process of interactions among employees especially, how they attach meaning to information and entrepreneurial networking patterns over time;—the study was conducted in Kampala district among trade, manufacturing, and services sectors only. The implication is that entrepreneurial networking can only be explained and predicted through ecologies of innovation. The study recommends that SME owners/managers need to fully understand and facilitate ecologies of innovation for employees to interact and attach meaning to information. This research contributes to the literature on mediation of ecologies of innovation between informational differences and entrepreneurial networking through its empirical findings of the hypothesised relationships. It theoretically contributes to existing knowledge by integrating complexity systems leadership theory.

Subjects: Entrepreneurship and Small Business Management; Small Business Management; Business and Planning

Keywords: informational differences; ecologies of innovation; entrepreneurial networking; SMEs; complexity

1. Introduction

Small and medium enterprises (SMEs) have historically been the main players in local economic activities, especially as large providers of employment and hence, a generator of primary or secondary sources of income for many households. SMEs are important engines for development of economies and communities in many countries of the world (Khan & Abasyn, 2017). The development of SMEs becomes a necessary intervention to enhance the local economic development. Abosede, Obasan, and Alese (2016) argue that vibrant SMEs are crucial to the process of overcoming poverty, inequality and unemployment. SMEs play a crucial role in people's effort to meet basic needs and help marginalised groups, such as female heads of households, disabled persons and rural families. Ueasangkomsate and Jangkot (2017) point out that the development of SMEs is interrelated to local economic development. SMEs are an engine to address the challenges of poverty, inequality and job creation. In Europe, more than 90% of businesses are SMEs, and they contribute more than 53% to the employment sector (Czarniewski, 2016). In sub-Saharan African countries, SMEs contribute 90% to the employment sector (Karadağ, 2016). Thus, the development and growth of SMEs has received attention from many governments around the world as a key tool for job creation, poverty alleviation, wealth creation, revenue generation and crime reduction. SMEs dominate the business sector in Sub-Saharan Africa accounting for 60% of the total number of enterprises (Peprah, Mensah, & Akosah, 2016).

Entrepreneurial networking generally refers to what entrepreneurs do in creating and shaping network ties and may therefore include tie formation and maintenance behaviours as well as any assemblage of such behaviours into unique networking styles, strategies or processes (Bensaou, Galunic & Jonczyk-Sédès, 2014; Porter & Woo, 2015; Vissa & Bhagavatula, 2012). Entrepreneurial networking is likely to be effective when there are ecologies of innovation in the business. Ecologies of innovation is creating enabling environment in which experiments in novelty lead to innovative practices, processes and routines, enabling an organisation to become adaptable to the unprecedented levels of change characterising today's business environments (Goldstein, Hazy, & Lichtenstein, 2010; Valkokari, 2015). Previous studies explored informational differences as the amount of information employees have about the markets. Managers assumed that employees have identical information sets, attach the same meaning irrespective of their backgrounds and that the conditions of information are similar (Diks & Dindo, 2008). Over the past few years, there has been a growing interest in informational differences and its predictive potential to

entrepreneurial networking (Yildiz, Alkan, Ateş, & Sezen, 2015). Informational differences emerge through the differences in members' backgrounds, skills, opinions, perspectives and experiments which help to drive innovation (Quintane, Mitch Casselman, Sebastian Reiche, Nylund, & Martín-De Castro, 2011). A closer scrutiny of these studies indicates that there is limited knowledge on the mediating role of ecologies of innovation in the relationship between informational differences and entrepreneurial networking among SMEs. Therefore, the study attempts to address the gap by testing for the mediating effect of ecologies of innovation in the relationship between informational differences and entrepreneurial networking among SMEs. We, therefore, conjecture that ecologies of innovation are a conduit through which informational differences affect entrepreneurial networking among SMEs.

In Uganda, the business sector has since the 1990' ****gained a commendable growth of 8% per annum contributing 28% to Uganda's GDP and to its growth by 37% (Uganda Bureau of Statistics (UBOS, 2017; World Bank, 2017). SMEs in Uganda establish informal and formal relations to assist individuals to pursue personal goals including business goals. The relations provide individuals and businesses with the required tangible and intangible resources through entrepreneurial networking (Fayolle, Jack, Lamine & Chabaud 2016). Entrepreneurial networking in Uganda forms the backbone of social and economic life. The structure of social relations between individuals in Uganda sometimes affects a community's economic development. More precisely, economic opportunities are more likely to come from contacts outside a tightly knit local friendship group or relatives. Although Uganda is rich in social networks, they are highly clustered, or insular;—social ties are predicted to limit access to social and economic prospects from outside the social group, whereas heterogeneous social ties may generate these opportunities from a range of diverse contacts (Rooks, Szirmai, & Sserwanga, 2012). Entrepreneurial networking is vital for individuals to benefit from social ties that bridge between communities. These benefits include access to;—materials, information, social support, money, power in negotiation, and opportunities for entrepreneurship. Entrepreneurial networking has partly contributed to high start-ups and growth. Uganda is ranked to be a more entrepreneurial country than the United States of America at 13% (Global Entrepreneurial Index 2017). Although Uganda is rich in social networks, 50% of SMEs do not celebrate their third birthday (Global Enterprise Monitor 2014). SMEs still struggle to manage informational differences, and create ecologies of innovation to effectively develop effective entrepreneurial networks for business competitiveness. Using qualitative factors for informational differences and ecologies of innovation to predict entrepreneurial networking, this study offers a unique dimension in understanding how SMEs in developing economies can be competitive in dynamic environment.

The rest of the paper proceeds as follows: The next section is literature review and hypothesis development, methodology, results, discussion, conclusion, implications and limitations of the study.

2. Literature review and development of hypotheses

2.1. Complexity systems leadership theory

Complexity systems leadership theory (CSLT) explains the mediating role of ecologies of innovation in the relationship between informational differences and entrepreneurial networking in the complex environment (Goldstein et al., 2010; Hazy, 2012; Lindhult & Hazy, 2016). The scholars cited earlier posit that higher levels of innovation could only be achieved through the emergent ecologies of innovation. Goldstein et al. (2010) argue that creating ecologies of innovation could be made possible by interaction resonance or symbiotic behaviour among employees. These further contend that alertness to unfolding-series of events tends to stimulate cohesiveness, ties, interactions and networking style among SME owners/managers (Haynie, Shepherd, & McMullen, 2009; Shane, 2003). SMEs identify and exploit opportunities because of the meaning attached to information differences among the employees who do things in an unusual way. CSLT can predict mixed multiple possible outcomes with divergent views. In this study, informational

differences and ecologies of innovation constructs are derived from CLST to explain entrepreneurial networking among SMEs. Thus, we offer the following hypotheses:

H1: There is a positive relationship between informational differences and entrepreneurial networking.

H2: There is a positive relationship between informational differences and ecologies of innovation.

H3: There is a positive relationship between ecologies of innovation and entrepreneurial networking

H4: Ecologies of innovation mediates the relationship informational differences and entrepreneurial networking.

2.2. Informational differences and entrepreneurial networking

Informational differences refer to witnessed smooth dissimilarities of opinion and knowledge among the employees. The management and employees attach value of dissimilarities in opinion and knowledge that influence their understanding of the business environment, and develop collaborations that connect those to formal and informal resources (Hazy & Uhl-Bien, 2015). Shane (2003) complements that informational differences amidst unfolding series of events acquaintance tend to generate opportunity tension, prompt opportunity recognition, trigger opportunity, evaluation and consequently opportunity exploitation that may require resources through entrepreneurial networking (Haynie et al., 2009). However, previous research on informational differences and entrepreneurial networking focused mainly on big organisations and corporations from developed economies and not SMEs in developing countries.

Hazy and Silberstang (2009) suggest that managers of businesses have a role to organise, gather, interpret, synthesise and disseminate information effectively as a system. Hence, individuals with such information play a significant role in facilitating an environment that is conducive for the exploration and experimentation of unfolding series of events emerging at every level of the organisation to foster ecologies of innovation process. It is by this exploration and experimentation that innovation grows even through a small “cut-off” in technology which vary from one business to another (McMillan, 2008). However, not all SMEs in developing countries possess the capacity to create a conducive environment for innovation because they may not have structures, policies and systems to manage Administered informational differences (AID). The informational differences foster these “events” to be known, get selected, and are then reinforced through a series of additional events (Goldstein et al., 2010). Complexity science academia reveals that positivist employees with that type of AID are key antecedents for identifying opportunities and entrepreneurial networks that support the business competitiveness. Kibirango, Munene, Balunywa, and Obbo (2017) argue that if AID is not well managed, it may cause frustrations among employees because they may fail to exploit an opportunity. Previous studies on these constructs were within organisations with strong structures and the findings cannot be generalised to developing economy context with high owner/manager control of employees and limited room for making errors without punishment (Karlesky, 2015).

In one of his complexity science articles, Goldstein, Hazy, and Silberstang (2008) declares that any sort of social network could only transmit information from one agent to another when these agents possess significant differences from one another. Without such differences, social network agents would disseminate more of the same information along the network (Baer, Evans, Oldham & Boasso 2015). This is likely to happen when management does not have the exposure of managing information differences and accessing resources from networks based on the meanings attached. This is likely to happen among SMEs because there are systematic steps SMEs can undertake to train their employees to attach meaning.

H1: There is a positive relationship between informational differences and entrepreneurial networking.

2.3. Informational differences and ecologies of innovation

To control the environment, the business must absorb into its internal structure the variations and informational differences that are apparent in the ecologies of innovation. One way of doing this is by increasing the number of possible states that the system can assume, and this can be done by increasing the possible variables or degrees of freedom of the system (Dougherty, 2017). Drawing from complexity systems leadership, this thinking implies that management of SMEs should encourage their employees to interact by creating an enabling environment to attach meaning to information based on their different backgrounds and perceptions in complex environments. However, Baltaci and Balci (2017) posit that it is not the case among SMEs because not all have structures to be more orderly and coherent to allow internal degrees of freedom since they have limited resources. Informational differences among individuals with such information do play a significant role in facilitating a conducive environment for the exploration and experimentation of unfolding series of events emerging at every level of the organisation to foster the ecologies of innovation when SMEs do have leaders and not managers (Paulišić, Tanković, & Hrvatin, 2016). Information is “a difference that can make a difference” (Hazy & Uhl-Bien, 2013).

In organisations, meaning emerges through the differences in member’s backgrounds, skills, opinions and perspectives and surprises from events, experiences and experiments, which help to drive innovation. Hence, innovations lie in deviations from what is expected from employees (Kibirango et al., 2017). Experiments in ecologies of innovation reflect departures from currently accepted and conventional ways of functioning (Hazy & Uhl-Bien, 2015). This does not always happen among SMEs because in developing countries, it is hard to separate the owner of the business from the structures that make decisions. In addition, not every manager is a leader who can make flexible policies instead of ruling by thumb. In case of developing countries, previous literature focused on developed economies where a business owner empowers the team to make professional decisions.

A huge amount of differences distinguishing one agent from another in a given system is one of the ways of distinguishing a complex from a simple system (Huse, 2014). Despite the fact that differences in assortment within a complex system renders such systems difficult to predict and control, it is the interactions among differences that set apart the agents; who mix and recombine the differences; and which gives complexity systems their potential for self-organisation; and emergence into new patterns with new properties (Boylan & Turner, 2017). This is what the complexity systems leadership scientists are trying to examine into predicting entrepreneurial networking. This is what Goldstein et al. (2010) refer to as positive deviance. In this aspect, positive deviance is the connotation, which tends to accept the way of doing something different or unplanned, even when it causes problems with others. Complexity systems leadership theory uses the principle of emergence to explain how the creation and re-creation of new organisations, re-emergence (transformation); the emergence of collaborations and the emergence of the entrepreneurial networking in complex environment (Lindhult & Hazy Huse, 2014).

H2: There is a positive relationship between informational differences and ecologies of innovation.

2.4. Ecologies of innovation and entrepreneurial networking

Developing ecology in an organisation through which innovations can emerge as strategic decision process involves employees from across the ecologies of innovation. Successful organisations adopt strategies that rely on establishing new connections, exchanges, and interchanges with various other players in its ecologies of innovation including creating linkages with social networks in the external environment (Boylan & Turner, 2017).

The arising of unforeseen new structures with unexpected new properties is what the study of radical innovation or complexity systems discussions termed as “emergence”. In organisations, emergence is the basis for innovations; the central process within influence;—precisely because it occurs through integration of “bottom-up” inspiration and the “top-down” guidance here referred to as generative influence (Goldstein et al., 2010). In studies conducted on ecologies of innovation, Järvi, Almpantopoulou, and Ritala (2018) argue that when combined, various processes of emergence yield true novelty, such as the creation of new ventures or renewed the organisation in a whole or part in developed economies where businesses run based on formal structures and policies. SMEs in developing countries find it hard to have bottom-up approach since the owner/manager tends to direct employees what to do as opposed to SMEs in developed economies where structures and systems are put in place to guide decision making to achieve the business goals.

Acs, Stam, Audretsch & O’Connor (2017) suggests that while ecologies of innovation can have different structures and origins, their success lies in their ability to create a cohesive social and economic system that supports the creation and growth of new ventures based on employees’ interactions. Ecologies of innovation create knowledge that is useful in the design of business plans and pitch ideas to business owners/managers to overcome the liability of newness when working with potential clients and suppliers. Thus, entrepreneurial networking is critical to accessing resources from formal and informal relations (Johannisson, 2017). Ecologies of innovation emphasise the interaction between the players in the ecosystem (with high network density, many connecting events, and large companies collaborating with local start-ups) and access to all kinds of relevant resources (talent, services, capital), with an enabling role to gain competitive advantage. SMEs from developing economies can learn from these practices if they understand how ecologies of innovation and entrepreneurial networking evolve in different environments.

H3: There is a positive relationship between ecologies of innovation and entrepreneurial networking

2.5. Informational differences, ecologies of innovation and entrepreneurial networking

The differences in information offer possible parallels in understanding each other (Hazy & Uhl-Bien, 2013). CSLT posits that in organisations it is difficult to trace individual interactions and how much individuals attach meaning to information. If the differences in information are well managed and get meaning out of disagreements, ecologies of information are promoted (Hazy & Prottas, 2016). This can happen among SMEs in developing countries when business owner/manager created enabling environment that allows employees to attach meaning to information based on their perceptions to understand new ways of doing things and access resources from networks.

In developing economies such as Uganda, employees’ failure to attach meaning to information differences affects the ecologies of innovation among SMEs. Individuals cultivate a way of sensing and mobilising interrelationships across natural (physical/environmental), mental (cognitive/conceptual) and social (ideological/human) spheres in a way that activates personal agency through perception and personal benefits. Individuals exclusively involved in their goal pursuit are involved in intentionally helping, hurting or even observing their process which impacts on their performance inadvertently such as by slowing a person’s ability to move quickly because of ecologies of innovation and entrepreneurial networking (Galkina, 2013). It is the informational differences that help individuals to interact and attach meaning to information that influences them to access resources through entrepreneurial networking since it is the gaps in information that people need to enhance their learning from ecologies of innovation in Uganda. Kibirango et al. (2017) argue that some businesses end up focusing on sets of data and fail to create enabling environment for the employees to attach meaning, which affects the access to resources and hence high failure rate.

Complexity systems leadership studies confirm that the ability to learn differently is an opportunity to assess or evaluate and implement the acquired knowledge through spontaneously

occurring experiments in innovative social practices at the “peripheries” (Lindhult & Hazy, 2016). These studies show that knowledge generation through informational differences require relevant structures, motivating policies, and a certain degree of freedom (ecologies of innovation). Diversity is, consequently, considered a source of adaptability to the new environment. SMEs in Uganda need to facilitate their employees to attach meaning to informational differences, and create an enabling environment for entrepreneurial networking for competitiveness. Previous studies were conducted in developed economies, and the SMEs have different characteristics from Ugandan context. This study contributes knowledge to SMEs in developing economies.

H4: Ecologies of innovation mediates the relationship informational differences and entrepreneurial networking.

3. Research design

The research, hypothetico-deductive in form, is motivated by a desire to better understand the antecedents to ecologies of innovation in mediating the relationship between informational differences and entrepreneurial networking among SMEs. A conceptual model informed by CSLT theory was specified initially. The positivist paradigm was used to emphasise the importance of acquiring knowledge through scientific methods of enquiry. Usage of this scientific approach involves correlational means (Major, 2017). Variables for testing were identified based on foregoing studies. Each variable was operationalised and included in a survey instrument. The survey instrument was pre-tested with 10 SMEs with more than five employees and had existed for more than one year, which is standard practice (Van Teijlingen & Hundley, 2010). No issues were raised with regard to understanding the questions or pre-defined response sets. Kampala district, the capital city of Uganda, was chosen because it has the highest number of SMEs in Uganda. They spread across all sectors with 49% in the service sector, 33% in the commerce and trade, 10% in manufacturing and 8% in other fields. Over 2.5 million people are employed in this sector, where they account for approximately 90% of the entire private sector, generating over 80% of manufactured output that contributes 20% of the gross domestic product (GDP), Uganda Investment Authority Report, 2016). With an entrepreneurship rate of 28%, Uganda ranks in first place with almost double the entrepreneurship rate of Thailand, who comes in second place with 16% (Global Entrepreneurship Monitor, report, 2014). As such, Uganda represents an unique context in which to test our model.

3.1. Operationalisation of variables

3.1.1. Informational differences

The study measured informational differences by considering the nature and quality of the network of human connections, communication capacity, as well as how the cognitive capacity of individuals within the network together form another independent constraining factor to achieve the desired objectives. In this study, information about what is happening in the system and the ecology is widely distributed among individuals and not immediately accessible for organised solutions (Quintane et al., 2011).

The confirmatory factor analysis (CFA) was carried out to test whether the dimensions of a theoretically grounded model of variables fitted in the study data based on model fit indices (Williams, Onsmann, & Brown, 2010), to confirm whether the factors extracted converged as manifest variables of the latent variable. Chi-square = 6.289; Degree of Freedom (DF) = 4, Probability (P) = .179; Incremental Fit Index (IFI) = .989; Goodness of Fit Index (GFI) = .989, Tucker Lewis Index (TLI) = .972; Comparative Fit Index (CFI) = .989; Normed Fit Index (NFI) = .971; Relative Fit Index (RFI) = .927; CMIN/DF = 1.572; Root Mean Square Error of Approximation (RMSEA) = .050. Results from the fit indices indicated a good model fit between the model and the observed data as indicated in Figure 1. The Cronbach’s alpha value was .791 and CVI was .800 which were acceptable, satisfy the norms of Hair, Black, Babin, and Anderson (2010).

Figure 1. Information differences.

Chi-square = 6.289; Degree of Freedom (DF) = 4, Probability (P) = .179; Incremental Fit Index (IFI) = .989; Goodness of Fit Index (GFI) = .989, Tucker Lewis Index (TLI) = .972; Comparative Fit Index (CFI) = .989; Normed Fit Index (NFI) = .971; Relative Fit Index (RFI) = .927; CMIN/DF = 1.572; Root Mean Square Error of Approximation (RMSEA) = .050 (Source: Primary data)

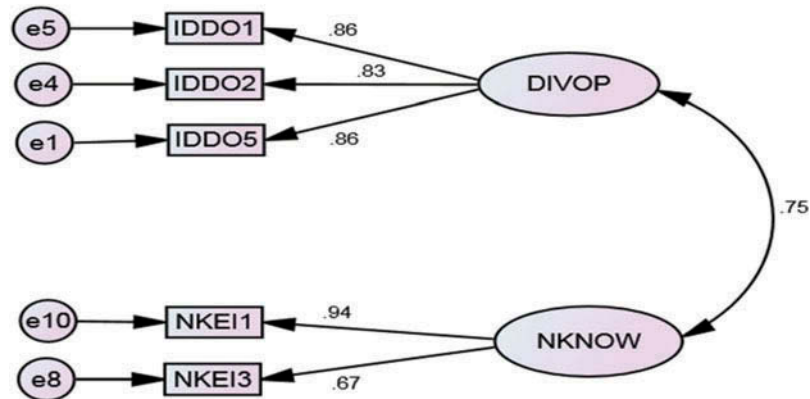

3.1.2. Ecologies of innovation

In this study, ecologies of innovation (EI) were reflected as a mediating variable. First, a unidimensional analysis was applied to this variable by examining the magnitude of unfolding-series of events witnessed and how they get known, get selected, the level of conformity or submission and how they are adopted and reinforced through networks. It was also examined as a process which is not led by any one individual but emerge through unfolding-series of events at every level of the organisation. This was done by considering interactions between ecosystems, eco subsystems, and their environments.

In the same manner, respondents were asked to assess the magnitude of unfolding-series of events witnessed and how they get known, get selected, the level of conformity or submission, how they are adopted and reinforced through social networks (Goldstein et al., 2010).

The CFA (Figure 2) had a good model fit; Chi-square = 28.018; Degree of Freedom (DF) = 28, Probability (P) = .463; Goodness of Fit Index (GFI) = .976, Tucker Lewis Index (TLI) = 0.946; Normed Fit Index (NFI) = .956. Relative Fit Index (RFI) = .930; Root Mean Square Error of Approximation (RMSEA) = .036. The model fit indices were all above the threshold of .95 and the RMSEA were less

Figure 2. CFA-Ecologies of innovation.

Chi-square = 28.018; Degree of Freedom (DF) = 28, Probability (P) = .463; Incremental Fit Index (IFI) = 1.000; Goodness of Fit Index (GFI) = .976, Tucker Lewis Index (TLI) = .946; Comparative Fit Index (CFI) = 1.000; Normed Fit Index (NFI) = .956; Relative Fit Index (RFI) = .930; CMIN/DF = 1.001; Root Mean Square Error of Approximation (RMSEA) = .036 (Source: primary data)

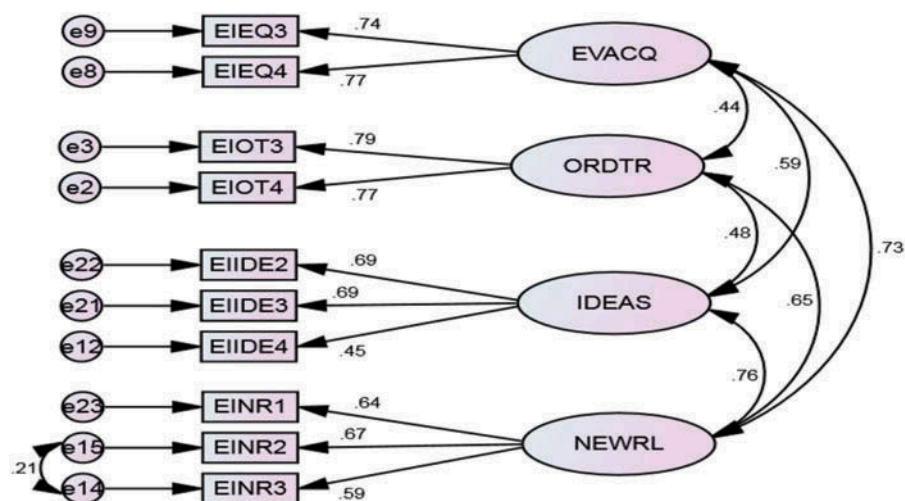

than the 0.05 cutoff point implying the retained items explained well the latent Variable. The Cronbach’s Alpha coefficient was .912 and CVI was .833, which were acceptable as they met the minimum value of 0.7 recommended by Nunnally (1978).

3.1.3. Entrepreneurial networking

The presence of strong and weak ties and a broad network appears to influence the persistence and success of entrepreneurs (Davidsson & Honig, 2003). The CFA retained interactions, ties, inter dependence and networking styles. It measured the relationships between contacts of the responding entrepreneur, resources like information, money, materials, social support and space. The CFA (Figure 3) showed a good model fit, Chi-square = 33.958; Degree of Freedom (DF) = 29, Probability (P) = .241; Goodness of Fit Index (GFI) = .971, Tucker Lewis Index (TLI) = .906; Normed Fit Index (NFI) = .937; Relative Fit Index (RFI) = .902; Root Mean Square Error of Approximation (RMSEA) = .027. The Cronbach’s alpha value was .919 and CVI was .850, which were acceptable, satisfy the norms of Hair et al. (2010). CFA enabled us to construct a model to describe meanings to entrepreneurial networking through interactions and networking styles. Our result revealed an accepted model fit based on several fit indexes, which were achieved as indicated in Figures 1-3 and Table 1. Therefore, CFA and SEM confirmed a model fit of all constructs.

3.1.4. Control of common methods variance (CMV)

The influence of CMV has been a pervasively cited concern in organisational research (Podsakoff, MacKenzie, Lee, & Podsakoff, 2003). A problem of CMV affects questionnaire-based studies in social sciences (Gorrell, Ford, Madden, Holdridge, & Eaglestone, 2011). This study does not materially have this problem because we performed an exploratory factor analysis where coefficients of 0.6 and above were considered sufficient in determining reliable scales (Dooley & Van de Ven, 1999; Neuman, 2006). Podsakoff and Organ (1986) describe the technique that if a substantial amount of common method variance is present, either a single factor will emerge from the factor analysis, or one “general” factor will account for the majority of the co-variance in the independent variable and criterion variables. As has already been indicated, all our variables have several factors explaining a single variable.

3.2. The survey process

This study adopted a cross-sectional descriptive research design to examine the role of ecologies of innovation in mediating the relationship between informational differences and entrepreneurial networking among SMEs in Uganda. In addition, a descriptive survey with a

Figure 3. Entrepreneurial networking.

Chi-square = 33.958; Degree of Freedom (DF) = 29, Probability (P) = .241; Incremental Fit Index (IFI) = .990; Goodness of Fit Index (GFI) = .971, Tucker Lewis Index (TLI) = .906; Comparative Fit Index (CFI) = .990; Normed Fit Index (NFI) = .937; Relative Fit Index (RFI) = .902; CMIN/DF = 1.171; Root Mean Square Error of Approximation (RMSEA) = .027 (Source: Primary data)

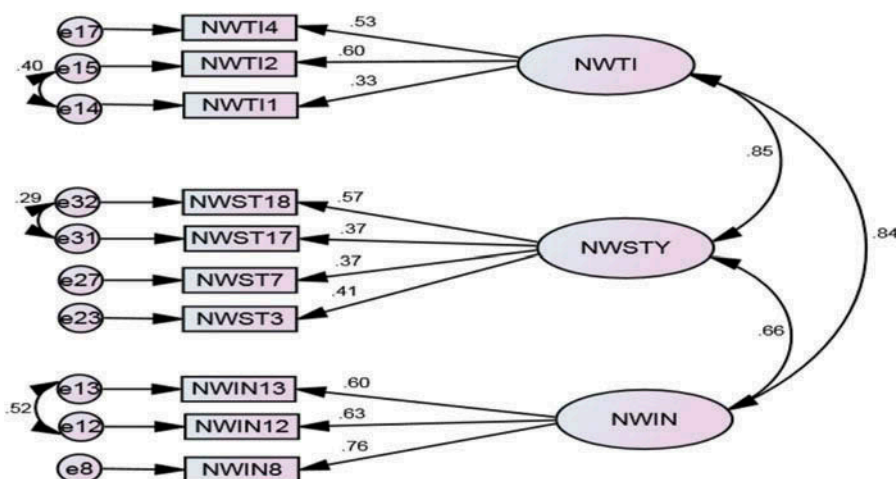

quantitative method constitutes the study's research design. The quantitative research design incorporated the standardised measures and statistical techniques associated with the positivist's paradigm to obtain responses on the three study variables. The total population consisted of 93,117 registered SMEs with more than five employees in Kampala district based on trade, services, and manufacturing sectors (UBOS, 2013). According to Krejcie and Morgan (1970) sample determination table, we targeted 392 respondents. The SMEs were chosen because of their high contribution to GDP and most of them are in Kampala business district. The businesses were selected using systematic sampling, and participants were selected using a purposive sampling technique.

3.3. Self-administered surveying

Self-administered surveying was the preferred approach for data collection. Principally, it permitted access to a large and geographically dispersed enterprise population quickly and with minimal outlay of resources. Self-administered surveying does come with caveats, particularly around common method variance (Chan, 2009). The data collection approach used was chosen because of the busy nature of our respondents. Additionally, the limited availability and efficiency of postal/communication services in Uganda are unfavourable for questionnaires to be mailed to our respondents.

As a precaution against threats to the validity of the data, advice offered by Podsakoff et al. (2003) was followed. Mainly, this involved only requesting information that respondents could reasonably be expected to know and willing to disclose, designing concise and easy to interpret scale items, limiting the total number of scale items to six and ensuring that respondents could participate without having to identify themselves or their SME.

First, the questionnaire was subjected to content validity test by distributing ten copies to experts, professionals, practitioners, and academia to vet if the items in it were deemed fit to measure the variables under this study. Content validity index (CVI) was obtained by dividing the proportion of items declared as valid by the total numbers of items as stipulated by Amin (2005). The responses were rated based on scales anchored on 1 representing relevancy, 2 representing somewhat relevant, and 3 representing irrelevancy of the items used in measuring the constructs. All the variables had CVI ranging between 0.79 and 0.92. All variables for the study were tested for validity and reliability as suggested by the literature (Blumberg, Cooper, Schindler, 2011; Sekaran & Bougie, 2010).

3.4. Data management

Raw data from the field were captured into SPSS (version 20) statistical analysis tool, and checks for data entry errors, missing values, outliers and normality were performed. Frequencies and descriptive statistics were generated to check for data entry errors and missing values, while Little's MCAR test was performed to check for the extent and pattern of missing values in our data. The results indicated that there were minimal data entry errors and our data were missing completely at random with Little's MCAR test significant at p -value less than 5%, which was acceptable for replacement (Field, 2005). The missing values in our data were replaced using series mean method of data imputation. Besides, box plots were used to determine the presence of outliers. However, there were no outliers sighted in our data. Therefore, this enabled us to proceed with test for assumptions of parametric data.

3.5. Tests for parametric assumptions

The test for assumptions of parametric data was performed based on normality and homogeneity of variance. The histogram, normal p - p plots, skewness and kurtosis, multicollinearity, and Levene's test for homogeneity of variances (linearity) were performed on our data. The results indicated that the histogram was bell shaped, indicating that our data were normally distributed. Besides, the normal p - p plots also indicated that the data were normal as most dots (observed

values) were falling along the straight line. Furthermore, skewness and kurtosis indicated that our data were normally distributed since all values were 0 as stipulated by Field (2005). Further analysis also indicated that multicollinearity was not a problem in our data since all our tolerance values were greater than 0.2 and variance inflation factors were less than 4 stipulated by Hair et al. (2010). The Levene's test result was non-significant at $p > 0.05$ showing that the variances were stable at all levels. Thus, all the tests confirmed that as assumptions of parametric data were achieved and tenable, and our data were good enough for further statistical analysis.

3.6. Response rate

Business owners/managers were drawn out of 392 samples. In each SME, two responses were eligible, and duplicate cases were eliminated. Thereafter, the screening process identified 36 substantially incomplete responses. Substantially incomplete responses are those that did not progress beyond the first section of the questionnaire, which was concerned with SME characteristics. Their elimination left the final number of usable responses at 228. The response rate of 58% was achieved.

3.7. Respondent characteristics

The results show the characteristics of SMEs, business owners/managers. With regard to the nature of businesses, majority were trade 102 (44%), services were 85 (37.3%), while manufacturing were 41 (18%). Among the businesses that the study focused on had existed more than 9 years counted 36%, while those which had existed 7–9 years were 35.5%. Most business owners/managers who responded to the questionnaires were male (62.4%) whereas female (37.6%). The results reveal that most owners or managers in the total sample were aged between 30 and 39 years (55.7%), followed by 18–29 years (26.7%). The number of years' individuals had worked with the organisation 3–6 years (44.8%), this was followed with 1–3 years (34.8%), respectively. The highest level of education among the business owners and managers was a degree at 83.3%, while 13.8% had Diploma and 2.9% had post graduate qualifications. Among the sample respondents, 91.3% were managers while 8.7% were business owners. This means that the respondents had a good understanding of entrepreneurial networking among SMEs in Uganda.

4. Results

4.1. Testing hypothesised model

The tested hypotheses were to examine the influence of informational differences on entrepreneurial networking; investigate the influence of informational differences on ecologies of innovation; examine the influence of ecologies of innovation on entrepreneurial networking; and examine the mediating role of ecologies of innovation in relationship between informational differences and entrepreneurial networking. The three hypothesised paths were statistically significant as discussed below (Table 1).

As it was suggested in hypothesis 1 (H1), informational difference is positively related to entrepreneurial networking. The results from the regression analysis indicated insignificant relationship between informational differences and entrepreneurial networking and ($\beta = 161, p > .05$), and thus the hypothesis was not supported. This suggests that positive changes in informational differences are not associated with positive changes in entrepreneurial networking of SMEs in Uganda.

Informational differences are positively related to the ecologies of innovation. The hypothesis examined the relationship between the informational differences and ecologies of innovation. The results show that there is a significant and positive relationship between informational differences and ecologies of innovation ($\beta = 424^{**}, p < .05$), and thus hypothesis (H2) was supported. This suggests that positive changes in informational differences are associated with positive changes in ecologies of innovation among SMEs in Uganda.

Ecologies of innovation are positively related to entrepreneurial networking. The hypothesis examined the relationship between the ecologies of innovation and entrepreneurial networking.

There is a significant and positive relationship between the ecologies of innovation and entrepreneurial networking ($\beta = .693^{**}$, $p < .05$), and thus the hypothesis (H3) was supported. This suggests that positive changes in ecologies of innovation are associated with positive changes in entrepreneurial networking among SMEs in Uganda.

Ecologies of innovation mediate the relationship between informational differences and entrepreneurial networking. The results in Table 1 show that the information differences are significant predictors of the ecologies of innovation at the 99% confidence interval level. Furthermore, it was noted that ecologies of innovation are significant predictors of the entrepreneurial networking ($\beta = .693$, sig. $< .01$) while the information differences are only a significant predictor of entrepreneurial networking in the direct regression model ($\beta = .415$, sig. $< .05$) and not in the mediated model ($\beta = .161$, $p > .05$). When the model was bootstrapped however while concurrently considering the mediator variable, the results in Table 2 show that standardised direct path effects from information differences to entrepreneurial networking are not statistically significant ($\beta = .161$, sig. > 0.05). However, the standardised indirect effect results showed that there is a statistically significant path from information differences to entrepreneurial networking ($\beta = .294$, sig. < 0.05), showing a partially mediated path by the ecologies of innovation. The results in Table 2 show that the standardised total effect of informational differences on entrepreneurial networking is significant ($\beta = .454$, $p < .01$). This result substantiates our hypothesis (H4). This indicated that inclusion of ecologies of innovation into the relationship resulted into full mediation. The unmediated model in show insignificant relationship between informational difference and entrepreneurial networking (Figure 4). Thus, ecologies of innovation are a critical conduit through which informational differences connect the entrepreneurial networking.

Table 1. Regression model

Mediated Model			Unstandardised Estimate	S.E.	C.R.	Standardised Estimate	p
ECOINN	←	IDIFF	.306	.085	3.606	.424	***
ETNET	←	ECOINN	.723	.195	3.715	.693	***
ETNET	←	IDIFF	.121	.105	1.156	.161	.248
Direct Regression							
ETNET	←	IDIFF	.462	.127	3.634	.415	***

P (two-tailed), *** $p < .01$. (Source: Primary data).

Table 2. Mediation test

Standardised Total Effects	IDIFF	ECOINN	ETNET
ECOINN	.424	.000	.000
ETNET	.454	.693	.000
Standardised Direct Effects	IDIFF	ECOINN	ETNET
ECOINN	.424	.000	.000
ETNET	.161	.693	.000
Standardised Indirect Effects	IDIFF	ECOINN	ETNET
ECOINN
ETNET	.294
P-value for Indirect effect	.004		
Mediation Supported	Yes		
Type of Mediation	Full		

(Source: Primary data).

Figure 4. Unmediated.

Chi-square = .690; Degree of Freedom (DF) = 1, Probability (P) = .406; Incremental Fit Index (IFI) = 1.004; Goodness of Fit Index (GFI) = .998, Tucker Lewis Index (TLI) = 1.023; Comparative Fit Index (CFI) = 1.000; Normed Fit Index (NFI) = .992; Relative Fit Index (RFI) = .952; CMIN/DF = .690; Root Mean Square Error of Approximation (RMSEA) = .000 (Source: Primary data)



4.2. Mediation effect results/regression

ID → EI → EN Mediation Model results

5. Discussion

This study examines the mediating effect of ecologies of innovation on the relationship between informational differences and entrepreneurial networking and found that it is a full mediator. There is no difference between standard total effect and indirect effect. This indicated that inclusion of ecologies of innovation into the relationship resulted into full mediation.

The results indicate that informational differences are insignificant predictor of entrepreneurial networking. This hypothesis (H1) was not supported. This means that emerging new ideas from divergent employees' opinion within the same environment do not warrant employees' access to resources from social networks. The knowledge that emerges from differences (due to employee backgrounds, skills, opinions, perspectives, surprises and different views) can be associated with enhanced frustrations and/or disagreements among the employees not to work in harmony to access resources from social networks. Karlesky (2015) argued that employee frustrations create the inability to facilitate learning within and outside the networks. Employees failure to attach meaning to informational differences can as well be another platform for reduced rational thinking to connect through interactions, and develop cohesiveness and ties to access tangible and intangible resources (Dougherty, 2017).

SMEs should endeavour to maintain systems capable of permitting employee interconnections and interacting among each other, management putting in place policies, flattened structures and a tolerance of failure type of governance culture that encourage employees to learn from mistakes and their interactions to access tangible and intangible resources from social networks. Management and employees who do not learn from informational differences caused by divergent opinions due to different backgrounds and exposure are likely not to share their conceived ideas. Even when they tend to instigate one—another from their respective positions, their creativity and innovativeness may not be enhanced without conducive internal environment (Hazy & Uhl-Bien, 2013). However, Bohnet and Saidi (2011) posit that SME managers may not necessarily facilitate the process of employees attaching meaning to informational differences because of inability to facilitate learning among employees. CSLT (Lindhult & Hazy, 2016) renders support to this finding that without management support, employees on their own are likely not to attach meaning to information that comes from different employees' perspectives, and this may result into employees failing to access tangible and intangible resources from entrepreneurial networks.

Informational differences and ecologies of innovation association were supported. This finding lends support to our hypothesis (H2). This means that informational differences are associated with ecologies of innovation. The findings suggest that the emerging new ideas from divergent employees' opinion, within the same environment, do warrant employees' creativity or innovativeness (Baltaci & Balci, 2017). The individual innovativeness can be facilitated through flattened SME structures. These harmonious interactions bond employees to express their conceived ideas for the betterment of the business. The meaning employees attach to informational differences is based on a network of interconnected and interactive relevant policies that guide the revolutionary process or avenues. The trial and error type of governance with tolerance, not only stimulate innovative employees' behaviour but also provides learning experience from which ideas are examined before adapted (Goldstein et al., 2010).

Kibirango et al. (2017) argued that employees who feel opportunity tension, but at the same time, they are also limited by informational differences which at first appear as differences in perspectives and disagreements in interpretation are unlikely to be creative. Thus, both opportunity tension and informational differences are important for business owner/manager to handle them well to succeed during difficult periods. To understand how this can be done, it is necessary to understand how a business becomes stable in the first place. Boylan and Turner (2017) revealed that it necessitates SME managers and all employees to fully understand the role of informational differences in creating ecologies of innovation for SME competitiveness. Adequate policies, structures and governance to facilitate symbiotic interactions and exchange of ideas fully act as a conduit and/or a reason for harmonious interactions, sharing of ideas and thereby enhancing SME employees' creativity or innovativeness (Acs, Autio, & Szerb, 2014). The CSLT (Lindhult & Hazy, 2016) renders support to the findings that management plays a vital role in creating an enabling environment for employees to have meaningful interactions that help them to attach meaning to different perspectives of their fellow employees and learn from their environment to do things differently from the usual routine.

The study established a significant positive relationship between ecologies of innovation and entrepreneurial networking. This supports our hypothesis (H3) of the study that ecologies of innovation offer opportunities for employees to access resources from social networks (Järvi et al., 2018). In a business, wherever ecologies of innovation are enhanced, entrepreneurial networking among employees in Uganda intensifies substantially as well. Lindhult and Hazy (2016) noted that ecologies of innovation like in complexity science, include employees' ties, interdependence and networking style operate in a co-evolution environment with relevant policies, structures and governance to facilitate emerging ideas from their network of interactions to access the required resources.

According to Goldstein et al. (2010), where SME management apply emergency of dynamism, tolerance of failure encourage employees to achieve desired goals, then they are likely to access resources from networks. Innovation occurs more effectively where there is an exchange of knowledge among employees. However, SMEs in developing economies have a challenge of establishing structures that make employees interacting and divert from the established policies. Whenever enabling environment is enhanced, networking is likely to be more effective. This normally happens in developed countries because their SMEs have structures and encourage divergent views with focus on learning from mistakes. The importance of diversity among employees helps in developing new ideas and relationships that help in dynamic networking for business support (Boylan & Turner, 2017).

Johannisson (2017) argued that SMEs that groom employees tend to be more informed on how to deal with prevailing challenges creatively, develop new ideas for venture creation are likely to network successfully. Employees tend to be informed when they learn from their social network agent's differences depending on an enabling environment, which provides a platform for enhanced rational thinking and creativity about accessing resources and mitigating negotiations

from network members. Although there is consensus that social networks provide resources, sometimes they negate the objectives of individuals and the business and networks end up not being beneficial.

Ecologies of innovation mediate the relationship between informational differences and entrepreneurial networking. The results established full mediation of ecologies of innovation in the relationship between informational differences and entrepreneurial networking among SMEs in Uganda. This implies that management on its own may not effectively network without creating an enabling environment (de Vasconcelos Gomes, Facin, Salerno, & Ikenami, 2018). Thus, Hazy and Uhl-Bien (2013) lends support to this study that ecologies of innovation are a conduit through which informational differences connect to entrepreneurial networking. This indicates that without ecologies of innovation, informational differences cannot be associated with entrepreneurial networking among SMEs. This is true when SMEs have relevant policies, and governance structures to facilitate emerging ideas from a network of interactions often benefit from employees' creativity or innovativeness. Hazy and Prottas (2016) revealed that enabling environment that connects employees to attach meaning to emerging ideas from a network of interactions (informational differences) enhances employees' creativity or innovativeness of SMEs. Entrepreneurial networking can be explained by informational differences through ecologies of innovation. Staff with divergent views, who can attach different meaning to information can only work together for common objectives when there is an enabling environment to harmonise the information originating from their network (Lindhult & Hazy 2014).

Informational differences through ecologies of innovation are true drivers of entrepreneurial networking. However, while the direct relationship between informational differences and entrepreneurial networking without ecologies of innovation was found to be insignificant, the relationship becomes significant when the mediation of ecologies of innovation is allowed. Therefore, ecologies of innovation significantly act as a conduit in the association between informational differences and entrepreneurial networking (Martiskainen 2017). CSLT supports this because it is management that should develop leadership skills to create an enabling environment for employees to interact and attach meaning to information and identify networks.

6. Conclusion, implications, limitations and future research

In this new science of complexity, scholars conceive that businesses and management structures are complex systems, which tend to facilitate informational differences that help employees to learn from each other when they attach meaning to information. The meaning attached to information is based on employees' backgrounds and perceptions. Employees are, therefore, advised to use information as a tool and the advantages of informational differences as a social intervention to help social systems identify and enhance novel experiments with problem solving and/or opportunity exploitation potential, which were previously unnoticed by accessing tangible and intangible resources from social networks. SME employees need guidelines to position, organise, gather, interpret, synthesise and disseminate information effectively as a system (Lindhult & Hazy, 2016). Hence, individuals with such information play a significant role in facilitating an environment that is conducive for the exploration and experimentation of unfolding series of events emerging at every level of the organisation to foster ecologies of innovation process.

The study concludes that ecologies of innovation fully mediate the relationship between informational differences and entrepreneurial networking. Therefore, ecologies of innovation significantly act as a conduit in the association between informational differences and entrepreneurial networking. Basically, such conducive internal working environment can be provided through a degree of freedom, and the tolerance of trials and error type of governance (Kibirango et al., 2017). Otherwise, these study findings, further, show that whenever motivated employees share their conceived ideas with others outside endorsed relevant and adequate governing policies, structures, and/or new embryonic approaches/method to sufficiently coordinate and facilitate the inter-

dependent emerging patterns, employee's creativity and innovativeness motivate them to access resources from entrepreneurial networks to gain competitiveness.

6.1. Implications for practice

The study results revealed important lessons to be taken by business owners/managers of SMEs and practitioners. The results from the study indicate the important role played by ecologies of innovation in creating a conducive environment for employees to interact; people of different backgrounds attach meaning to information and come up with innovations to access resources from formal and informal relations for SMEs to achieve their objectives. Besides, as a key point to note, ecologies of innovation as a mediator continue to be a major factor in influencing entrepreneurial networking among SMEs in Uganda. This is supported by the fact that innovations cannot take place without business owners/managers creating a conducive environment for employees to interact and attach the value of dissimilarities in opinion and knowledge that influence their understanding of the business environment.

From a policy perspective, existing efforts should note that possessing information is not enough to improve entrepreneurial networking among SMEs in Uganda. Therefore, a blend of informational differences with ecologies of innovation among SMEs may cause greater improvement in the level of entrepreneurial networking. Ecologies of innovation amplify perspectives and surprises from events, experiences and experiments which help to drive innovations that require resources to be accessed from formal and informal relations. Thus, business owners/managers should have policies that guide employees to focus on facilitating self-organising process conducive for creativity and innovativeness for employees to continue interacting with their networks and access tangible and intangible resources.

Additionally, business owners/managers in Uganda should also encourage employees to learn from others since different people are exposed differently and also attach meaning to the information differences other than engaging in needless conflict. It is the meaning attached that motivate people to interact and work together to become innovative. For researchers, there is a need to understand the mediating role of ecologies of innovation between informational differences and entrepreneurial networking among SMEs. Studies that focus on how ecologies of innovation are created while replicating entrepreneurial networks may be vital in future.

6.2. Limitations and future research

First, prior research in decision making has shown that respondents are not good at capturing their own behaviour (Neuman 2007), resulting in potentially inaccurate representations of behavioural tendencies. In this study, subjective appraisals were used, which requires future research to generate and include more objective and triangulation measures.

Second, different cultural contexts affect how people behave during entrepreneurial networking. Previous entrepreneurial networking studies have shown that there is a relationship between entrepreneurial networking and culture (Shane, 2003). Caution about generalising the results of this study should be taken especially when comparing it with other regions. Third, the cross-sectional nature of this study has been critiqued that renders assertions regarding the direction of causality tentative. Longitudinal studies should be conducted to trace how SME managers/owners attach meaning to information, what kind of relationships they establish and resources accessed over period of time.

Funding

The authors received no direct funding for this research.

Author details

Samuel Mayanja¹
E-mail: smayanja@cavendish.ac.ug

E-mail: ssekajjasam@gmail.com

ORCID ID: <http://orcid.org/0000-0002-6780-4041>

Joseph M. Ntayi²

E-mail: jntayi@mubs.ac.ug

J.C. Munene³

E-mail: jcmunene@mubs.ac.ug

Waswa Balunywa⁴
E-mail: wbalunywa@mubs.ac.ug
Arthur Sserwanga⁴
E-mail: asserwanga@mubs.ac.ug
James R.K. Kagaari⁵
E-mail: jmskagaari@gmail.com

¹ School of Post Graduate Studies and Research, Cavendish University Uganda, Kampala, Uganda.
² Faculty of Economics, Energy and Management Science, Makerere University Business School, Kampala, Uganda.
³ Faculty of Graduate Studies and Research, Makerere University Business School, Kampala, Uganda.
⁴ Makerere University Business School.
⁵ Department of Psychology, Kyambogo University, Kampala, Uganda.

Citation information

Cite this article as: Informational differences and entrepreneurial networking among small and medium enterprises in Kampala, Uganda: The mediating role of ecologies of innovation, Samuel Mayanja, Joseph M. Ntayi, J.C. Munene, Waswa Balunywa, Arthur Sserwanga & James R.K. Kagaari, *Cogent Business & Management* (2019), 6: 1617020.

References

- Abosede, A. J., Obasan, K. A., & Alese, O. J. (2016). Strategic management and Small and Medium Enterprises (SMEs) development: A review of literature. *International Review of Management and Business Research*, 5(1), 315.
- Acs, Z. J., Autio, E., & Szerb, L. (2014). National systems of entrepreneurship: Measurement issues and policy implications. *Research Policy*, 43(3), 476–494. doi:10.1016/j.respol.2013.08.016
- Acs, Z. J., Stam, E., Audretsch, D. B., & O'Connor, A. (2017). The lineages of the entrepreneurial ecosystem approach. *Small Business Economics*, 49(1), 1–10. doi:10.1007/s11187-017-9864-8
- Amin, E. (2005). *Social science research*. Kampala, Uganda: Makerere University Printery.
- Baltaci, A., & Balci, A. (2017). Complexity leadership: A theoretical perspective. *International Journal of Educational Leadership and Management*, 5(1), 30–58. doi:10.17583/ijelm.2017.2435
- Bensaou, B. M., Galunic, C., & Jonczyk-Sédès, C. (2014). Players and purists: Networking strategies and agency of service professionals. *Organization Science*, 25(1), 29–56. doi:10.1287/orsc.2013.0826
- Blumberg, B., Cooper, D. R., & Schindler, P. S. (2011). *Business research methods* (3rd ed., European ed.). New York, NY: McGraw-Hill Education.
- Bohnet, I., & Saidi, F. (2011). *Informational differences and performance: Experimental evidence* (Working Paper). Harvard Kennedy School.
- Boylan, S. A., & Turner, K. A. (2017). Developing organizational adaptability for complex environment. *Journal of Leadership Education*, 16(2), 183–198. doi:10.12806/V16/I2/T2
- Chan, D. (2009). So why ask me? Are self-report data really that bad. In *Statistical and methodological myths and urban legends: Doctrine, verity and fable in the organizational and social sciences* (pp. 309–336).
- Czarniewski, S. (2016). Small and medium-sized enterprises in the context of innovation and entrepreneurship in the economy. *Polish Journal of Management Studies*, 13. doi:10.17512/pjms.2016.13.1.03
- Davidsson, P., & Honig, B. (2003). The role of social and human capital among nascent entrepreneurs. *Journal of Business Venturing*, 18(3), 301–331. doi:10.1016/S0883-9026(02)00097-6
- de Vasconcelos Gomes, L. A., Facin, A. L. F., Salerno, M. S., & Ikenami, R. K. (2018). Unpacking the innovation ecosystem construct: Evolution, gaps and trends. *Technological Forecasting and Social Change*, 136, 30–48. doi:10.1016/j.techfore.2016.11.009
- Diks, C., & Dindo, P. (2008). Informational differences and learning in an asset market with boundedly rational agents. *Journal of Economic Dynamics and Control*, 32(5), 1432–1465. doi:10.1016/j.jedc.2007.06.003
- Dooley, K., & Van de Ven, A. (1999). Explaining complex organizational dynamics. *Organization Science*, 10(3), 358–372. doi:10.1287/orsc.10.3.358
- Dougherty, D. (2017). Organizing for innovation in complex innovation systems. *Innovation*, 19(1), 11–15. doi:10.1080/14479338.2016.1245109
- Fayolle, A., Jack, S. L., Lamine, W., & Chabaud, D. (Eds.). (2016). *Entrepreneurial process and social networks: A dynamic perspective*. Edward Elgar Publishing.
- Field, A. (2005). *Discovering statistics using SPSS* (2nd ed.). London: Sage.
- Galkina, T. (2013). *Entrepreneurial networking: Intended and unintended processes*. Global Entrepreneurship and Development Index. 2017
- Goldstein, J., Hazy, J., & Lichtenstein, B. B. (2010). *Complexity and the nexus of leadership: Leveraging nonlinear science to create ecologies of innovation*. New York: Palgrave Macmillan.
- Goldstein, J. A., Hazy, J. K., & Silberstang, J. (2008). Complexity and social entrepreneurship: A fortuitous meeting. *Emergence: Complexity and Organization*, 10(3), 9.
- Gorrell, G., Ford, N., Madden, A., Holdridge, P., & Eaglestone, B. (2011). Countering method bias in questionnaire-based user studies. *Journal of Documentation*, 67(3), 507–524. doi:10.1108/002204111111124569
- Hair, J., Black, W. C., Babin, B. J., & Anderson, R. E. (2010). *Multivariate data analysis* (7th ed.). Upper saddle River, NJ: Pearson Education International.
- Haynie, J. M., Shepherd, D. A., & McMullen, J. S. (2009). An opportunity for me? The role of resources in opportunity evaluation decisions. *Journal of Management Studies*, 46(3), 337–361. doi:10.1111/joms.2009.46.issue-3
- Hazy, J. K. (2012). Leading large: Emergent learning and adaptation in complex social networks. *International Journal of Complexity in Leadership and Management* 14, 2(1–2), 52–73. doi:10.1504/IJCLM.2012.050395
- Hazy, J. K., & Ashley, A. (2011). Unfolding the future: Bifurcation in organizing form and emergence in social systems. *Emergence: Complexity & Organization*, 13(3), 57–79.
- Hazy, J. K., & Prottas, D. J. (2016). *Robert B. Willumstad School of Business*.
- Hazy, J. K., & Silberstang, J. (2009). Leadership within emergent events in complex systems: Micro-enactments and the mechanisms of organisational learning and change. *International Journal of Learning and Change*, 3(3), 230–247. doi:10.1504/IJLC.2009.024690
- Hazy, J. K., & Uhl-Bien, M. (2013). Changing the rules: The implications of complexity science for leadership research and practice. In *Oxford handbook of leadership and organizations*. doi:10.1093/oxfordhb/9780199755615.013.033
- Hazy, J. K., & Uhl-Bien, M. (2015). Towards operationalizing complexity leadership: How generative, administrative and community-building leadership practices enact organizational outcomes. *Leadership*, 11(1), 79–104. doi:10.1177/1742715013511483

- Hülshager, U. R., Anderson, N., & Salgado, J. F. (2009). Team-level predictors of innovation at work: A comprehensive meta-analysis spanning three decades of research. *Journal of Applied Psychology, 94*(5), 1128. doi:10.1037/a0015978
- Huse, M., (2014). *The role of networks in the entrepreneurial process—A case study of three Norwegian craft breweries* (Master's thesis).
- Järvi, K., Almpantopoulou, A., & Ritala, P. (2018). Organization of knowledge ecosystems: Prefigurative and partial forms. *Research Policy, 47*(8), 1523–1537. doi:10.1016/j.respol.2018.05.007
- Johannisson, B. (2017). Networking and entrepreneurial growth. *The Blackwell Handbook of Entrepreneurship, 368–386*.
- Karadağ, H. (2016). *The role of SMEs and entrepreneurship on economic growth in emerging economies within the post-crisis era: An analysis from Turkey*.
- Karlesky, M. J. (2015). *Identifying entrepreneurial opportunities: Cognition and categorization in nascent entrepreneurs*.
- Khan, M., & Abasyn, J. (2017). An exploratory evidence of the types of challenges and opportunities perceived by the Small and Medium Enterprises (SMEs) in the apparel export sector of Pakistan. *University Journal of Social Sciences, 10*(2), 373–395.
- Kibirango, M. M., Munene, J. C., Balunywa, W. J., & Obbo, J. K. (2017). Mediation effect of novelty ecosystems on intrapreneurial behaviour process within an organisational dynamic environment among Kenyan universities: A complexity approach. *Journal of Organizational Change Management, 30*(6), 957–977. doi:10.1108/JOCM-08-2016-0157
- Krejcie, R. V., & Morgan, D. W. (1970). Determining sample size for research activities. *Educational and Psychological Measurement, 30*(3), 607–610. doi:10.1177/001316447003000308
- Lindhult, E., & Hazy, J. K. (2016). Complexity approach to joint value discovery in service innovation management. *International Journal of Complexity in Leadership and Management, 3*(1–2), 115–138. doi:10.1504/IJCLM.2016.075046
- Major, M. J. (2017). Positivism and “alternative” accounting research. *Revista Contabilidade & Finanças, 28* (74), 173–178. doi:10.1590/1808-057x201790190
- McMillan, E. (2008). *Complexity, management and the dynamics of change: Challenges for practice*. Routledge.
- Neuman, W. (2006). *Social research methods: Qualitative and quantitative approaches* (6th ed.). Boston: Pearson.
- Nunnally, J. (1978). *Psychometric methods*.
- Paulišić, M., Tanković, A. Č., & Hrvatin, M. (2016, January). Managing the service concept in creating an innovative tourism product. In 23. *bijenalni međunarodni znanstveno-stručni kongres "Turizam i hotelska industrija 2016: trendovi i izazovi"*.
- Peprah, J. A., Mensah, A. O., & Akosah, N. B. (2016). Small and medium sized Enterprises (SMEs) accessibility to public procurement: SMEs entity perspective in Ghana. *European Journal of Business and Social Sciences, 4*(11), 25–40.
- Podsakoff, P. M., MacKenzie, S. B., Lee, J., & Podsakoff, N. P. (2003). Common method biases in behavioral research: A critical review of the literature and recommended remedies. *Journal of Applied Psychology, 88*, 879–903. doi:10.1037/0021-9010.88.5.879
- Podsakoff, P. M., & Organ, D. W. (1986). Self-reports in organizational research: Problems and prospects. *Journal of Management, 12*(4), 531–544. doi:10.1177/014920638601200408
- Porter, C. M., & Woo, S. E. (2015). Untangling the networking phenomenon: A dynamic psychological perspective on how and why people network. *Journal of Management, 41*(5), 1477–1500. doi:10.1177/0149206315582247
- Quintane, E., Mitch Casselman, R., Sebastian Reiche, B., Nylund, P. A., & Martín-De Castro, G. (2011). Innovation as a knowledge-based outcome. *Journal of Knowledge Management, 15*(6), 928–947. doi:10.1108/13673271111179299
- Rooks, G., Szirmai, A., & Sserwanga, A. (2012). Network structure and innovative performance of African entrepreneurs: The case of Uganda. *Journal of African Economies, 21*(4), 609–636. doi:10.1093/jae/ejs011
- Sekaran, U., & Bougie, R. (2010). *Research methods for business: A skill building approach* (5th ed.). NJ: John Wiley and Sons.
- Shane, S. A. (2003). *A general theory of entrepreneurship: The individual-opportunity nexus*. Edward Elgar Publishing.
- Statistics, U. B. O. (2013). *Statistical abstract*. Kampala: Uganda Bureau of Statistics.
- UBOS. (2017). *Uganda national household survey FY 2016/17*. Uganda Bureau of Statistics.
- Ueasangkomsate, P., & Jangkot, A. (2017). Enhancing the innovation of small and medium enterprises in food manufacturing through triple helix agents. *Kasetsart Journal of Social Sciences, 2017*. doi:10.1016/j.kjss.2017.12.007
- Valkokari, K. (2015). Business, innovation, and knowledge ecosystems: How they differ and how to survive and thrive within them. *Technology Innovation Management Review, 5*(8), 17–24. doi:10.22215/tim-review/919
- Van Teijlingen, E., & Hundley, V. (2010). The importance of pilot studies. *Social Research Update, 35*, 49–59.
- Vissa, B., & Bhagavatula, S. (2012). The causes and consequences of churn in entrepreneurs' personal networks. *Strategic Entrepreneurship Journal, 6*(3), 273–289. doi:10.1002/sej.v6.3
- Williams, B., Onsmann, A., & Brown, T. (2010). Exploratory factor analysis: A five-step guide for novices. *Australasian Journal of Paramedicine, 8*, 3. doi:10.33151/ajp.8.3.93
- World Bank. (2017). *Uganda economic update, 10th edition, december 2017: Accelerating Uganda's development, ending child marriage, educating girls*. World Bank. Washington: Author.
- Yıldız, B., Alpkan, L., Ateş, H., & Sezen, B. (2015). Determinants of constructive deviance: The mediator role of psychological ownership. *International Business Research, 8*(4), 107–121. doi:10.5539/ibr.v8n4p107



© 2019 The Author(s). This open access article is distributed under a Creative Commons Attribution (CC-BY) 4.0 license.

You are free to:

Share — copy and redistribute the material in any medium or format.

Adapt — remix, transform, and build upon the material for any purpose, even commercially.

The licensor cannot revoke these freedoms as long as you follow the license terms.

Under the following terms:

Attribution — You must give appropriate credit, provide a link to the license, and indicate if changes were made.

You may do so in any reasonable manner, but not in any way that suggests the licensor endorses you or your use.

No additional restrictions

You may not apply legal terms or technological measures that legally restrict others from doing anything the license permits.



***Cogent Business & Management* (ISSN: 2331-1975) is published by Cogent OA, part of Taylor & Francis Group.**

Publishing with Cogent OA ensures:

- Immediate, universal access to your article on publication
- High visibility and discoverability via the Cogent OA website as well as Taylor & Francis Online
- Download and citation statistics for your article
- Rapid online publication
- Input from, and dialog with, expert editors and editorial boards
- Retention of full copyright of your article
- Guaranteed legacy preservation of your article
- Discounts and waivers for authors in developing regions

Submit your manuscript to a Cogent OA journal at www.CogentOA.com

