

See discussions, stats, and author profiles for this publication at: <https://www.researchgate.net/publication/328980651>

Mediating Effects of Network Degree and Network transitivity on the Relationship between Project Communication Strategies and Perceived Project Success. International Journal of Ec...

Article · January 2012

CITATION

1

READS

78

3 authors, including:



Arthur Ahimbisibwe
Makerere University

29 PUBLICATIONS 33 CITATIONS

SEE PROFILE



Sudi Nangoli
Makerere University Business School

30 PUBLICATIONS 130 CITATIONS

SEE PROFILE

Some of the authors of this publication are also working on these related projects:



Project Management CSFs [View project](#)

Mediating Effects of Network Degree and Network transitivity on the Relationship between Project Communication Strategies and Perceived Project Success

Arthur Ahimbisibwe¹, Sudi Nangoli² and Wilson Tusiime³

¹ Corresponding Author, Victoria Business School, Victoria University of Wellington, P. O Box 600, New Zealand
E-mail: arthur.ahimbisibwe@vuw.ac.nz

² Faculty of Commerce, Makerere University Business School, P. O Box 1337, Kampala, Uganda
E-mail: snangoli@mub.ac.ug

³ Faculty of Computing and Management Science, Makerere University Business School, P. O Box 1337, Kampala, Uganda
E-mail: wtusiime@mubs.ac.ug

ABSTRACT

The purpose of this study is to examine the mediating effects of social networks dimensions of network degree and network transitivity on the relationships between project communication strategies and perceived project success. This study was motivated by the increased failure of most philanthropic projects in Uganda to meet their explicit objects in terms of time, quality, and budget and enhanced corporate awareness which could be attributed to neglect of 'soft' factors. Although numerous classical studies have been undertaken in different domains involving project communication, social networks and perceived project success, no existing empirical study has examined the mediating effect of social networks dimensions on this relationship. A cross sectional data collected by a quantitative survey from all philanthropic projects conducted by commercial banks in Uganda, reveals that network degree is a significant mediator in the relationship between internal project communication and perceived project success while network transitivity is also a significant mediator in the relationship between external project communication and perceived project success. Further, the findings confirm a partial mediation between project communication, social network dimensions and perceived project success. This study has both practical and theoretical implications that are well discussed.

Keywords: *Mediation, Social Networks, Project Communication, Perceived Project Success*

1.0 INTRODUCTION

Today, many organisations have implemented project management as a means to achieve their operational and strategic goals. Similarly, most commercial banks globally have now invested heavily in philanthropic projects' as a means of improving their clientele base (Hopkins, 2007; McDonald & Rundle-Thiele, 2008). Consequently, many commercial banks are becoming more involved in welfare activities like improving education, poverty levels and public health in Sub-Saharan Africa especially in Uganda (Barclays bank sustainability review report, 2007), because research has shown that superior firm performance is positively associated with the success of philanthropic projects (Hopkins, 2007; Scott, 2007). Philanthropic projects can be defined as those projects that aim at making a positive difference in one's society welfare (Drucker, 1993). Despite this increased growth of projects, most philanthropic projects in Uganda fail to meet their explicit objectives in terms of quality, time, budgets, and scope and subsequently cannot create awareness among others (Nangoli, 2010). This could possibly be attributed to lack of effective project communication (Ramsing, 2009; Ruuska, 1996) and lack of adequate social networks (Andrews, 2007; Downes, 2005; Granovater, 1973).

Despite many studies that have cited project communication and social networks as critical success factors of project success (Pinto & Slevin, 1988; Cockburn & Highsmith, 2001; Shenhar et al., 2002; Sauser et al., 2009; Howell et al., 2010), no existing empirical study has fully examined the mediating role of social networks in this

relationship. Consequently, this creates lack of meaningful interpretation of findings; making it difficult for project managers and researchers to make correct conclusions and draw implications for project success.

Crawford and Pollack's (2004, p.645) study revealed that the success of any project is based on critical success factors that have been loosely categorised and ambiguously referred to as 'hard' and 'soft' factors. The 'hard' factors include all those that inherited their hard assumptions about the world, are rooted in positivist and realist philosophies; emphasize the search for objective knowledge while promoting an understanding of the world as an objective reality to which all people have equal and unvarying access (Cavana, Delahaye & Sekaran, 2001, p.8; Yeo, 1993;). Consequently, systems are viewed as mechanistic processes, with stable relationships between variables and are interpreted through the functional analysis that attempt to understand a system in terms of its purpose. In contrast, the soft factors are those which are based on interpretivism including critical theory and social construction. In summary the 'hard' and 'soft' aspects of project management are linked to ontological and epistemological philosophies respectively.

Therefore, the identification and response to these differences between 'hard' and 'soft' aspects of projects influences the perceived success (Crawford & Pollack, 2004). It is not only essential to recognise the differences but also to develop approaches which will bring their respective success rates together. Earlier, findings by Wateridge (1999) revealed that projects have been perceived to have failed due to project managers not paying attention to soft criteria. This implies that the 'hard' and 'soft' dichotomy poses a requirement for different managerial skills and styles. Despite the available evidence, most research has been focused on hard factors rather than soft factors. Subsequently, very few studies in project success have focused on the role of interpersonal factors and yet anecdotal evidence reveals that these factors play a significant role. Simply, projects are about managing expectations that have to do with perceptions of success. Although 'soft' issues have also been anecdotally identified as key success factors in project success and some times having a high impact than hard factors, defining what is 'hard' and 'soft' issues remains ambiguous in project success. Similarly, the divergence of expectations and perceptions from different stakeholders makes the concept of project success more difficult to evaluate.

There is indeed, an urgency to ensure that philanthropic projects that commercial banks invest in meet their expectations. If this situation does not improve and philanthropic projects continue to fail, banks that invest in these projects will continue to lose a lot of money, more people will continue to suffer from poverty, miserable life and increased death rates. Therefore the purpose of this study is to examine the mediating effects of social networks dimensions of network degree and network transitivity on the relationship between project communication strategies and perceived project success of philanthropic projects. This study therefore aims at answering the following research question: *Do social networks dimensions of network degree and network transitivity have a mediating effect in the relationship between project communication strategies and perceived project success in philanthropic projects?* In so doing, we make a significant contribution towards understanding the relationship between these study variables and create a meaningful interpretation of findings; thereby making it easy for project managers and researchers to make correct conclusions and implications for project success. The rest of this research paper is organised as follows, the next section examines theoretical foundations and reviews literature to develop hypotheses for validating the research model; followed by research methodology and results from data analysis. Finally, concludes with discussion of findings and implications, limitations and directions for future research.

2.0 THEORETICAL FOUNDATIONS, LITERATURE REVIEW AND HYPOTHESES

This section examines theoretical underpinnings of the study concepts, reviews literature in order to develop hypotheses for validating the research model.

2.1 Argumentation theory, Cognitive dissonance theory, Elaboration Likelihood Model and uncertainty reduction theory: In order to examine and describe carefully the relevance of project communication in perceived project success, the researchers have greatly cited from argumentation theory, Cognitive dissonance theory, Elaboration Likelihood Model and uncertainty reduction theory. The proponents of argumentation theory such as Eemeren et al. (1996), argue that communication, generally involves verbal and social activity of reason aimed at increasing (or decreasing) the acceptability of a controversial standpoint for the listener or reader, by putting forward a constellation of propositions intended to justify (or refute) the standpoint before a rational judge. Similarly, the Cognitive dissonance which is a communication theory adopted from social psychology views cognitive as thinking or the mind and dissonance as inconsistency or conflict. Cognitive dissonance is therefore the psychological conflict from holding two or more incompatible beliefs simultaneously (Dickerson, Thibodeau, & Miller, 1992). This theory views individuals as more purposeful decision makers who

strive for balance in their beliefs. If presented with information that creates dissonance, they use dissonance-reduction strategies to regain equilibrium, especially if the dissonance affects their self-esteem. In addition, this theory suggests that 1) dissonance is psychologically uncomfortable enough to motivate people to achieve consonance, and 2) in a state of dissonance, people will avoid information and situations that might increase the dissonance (Dickerson et al., 1992).

Further, Petty and Cacioppo (1986) argue that the Elaboration Likelihood Model (ELM) is based on the idea that attitudes are important because attitudes guide decisions and other behaviours. Essentially, while attitudes can result from a number of things, persuasion is the primary source. The ELM model therefore features two routes of persuasive influence; central and peripheral. The ELM accounts for the differences in persuasive impact produced by arguments that contain ample information and cogent reasons as compared to messages that rely on simplistic associations of negative, and positive attributes to some object, action or situation. Similarly, the proponents of uncertainty reduction theory argue that people communicate to reduce uncertainty because it is unpleasant (Heath & Bryant, 2000). Uncertainty reduction follows a pattern of developmental stages (entry, personal, exits). During the entry stage information about another's demographic information is obtained and much of the interaction in this entry phase is controlled by communication rules and norms. When communicators begin to share attitudes, beliefs, values, and more personal data, the personal stage begins. The communicators feel less constrained by rules and norms and tend to communicate more freely with each other. Finally, the communicators decide on future interaction plans.

2.2 Social network theory: Social network theory explains the relationships between individuals, groups, organizations, or societies to analyze social structures determined by such interactions. According to Downes (2005, P.411) and Scott (2000), social network theory explains social relationships in terms of nodes and ties; nodes are the individual actors within the networks and ties are the relationships between the actors. There can be many kinds of ties between the nodes however in its most simple form; a social network is a map of all of the relevant ties between the nodes being studied (Fowler, Dawes & Christakis, 2009). The network can also be used to determine the social capital of individual actors (Ntayi, Rooks, Eyaa & Qian, 2010).

Social networks can be examined at micro level, meso level and macro levels. For example a dyad is a social relationship between two individuals at the micro level. When one individual is added to a dyad, a triad is formed. Analyses at this level may concentrate on factors such as balance and transitivity, as well as social equality and tendencies toward reciprocity. This simply implies that the smallest unit of analysis in a social network is an individual in their social setting. In addition, at a Meso-level, network theories study population size that falls between the micro-levels and macro-levels. Examples are formal organizations that are social groups that distribute tasks for collective goals. The focus here is on either intra-organizational or inter-organizational ties in terms of formal or informal relationships; while Macro-level analyses generally trace the outcomes of interactions, such as economic or other resource transfer interactions over a large population. Examples are complex networks which involves substantial non-trivial features of network topology, with patterns of complex connections between elements that are neither purely regular nor purely random.

2.3 Project Communication and Social Networks: According to Downes (2005, P.411) social networks are a collection of individuals linked together by a set of relations. Entities in a network are called 'nodes' and the connections between them are called 'ties' (Downes, 2005). According to Fowler et al. (2009), social networks can be fundamentally discussed in terms of degree and transitivity. Social network degree is the number of social ties the project has. Network degree is at times referred to as network size. On the other hand, network transitivity refers to the likelihood that two of a persons' contact are connected to each other. It transforms into the level of trust members give themselves. The establishment, development, defence and maintenance of network positions is done by developing multiple relationships in the focal net i.e. in the relevant network in which the firm is active by relating externally and adapting internally. Ntayi et al. (2010) alludes that the strength of the linkage (relationship) grows through a history of interactions in which members of a network develop friendship and trust. The above statement points to the fact that stronger relations in a network could be fostered through effective project communication over time. Herkt (2007) affirms that the project manager's major responsibility is to build supportive social networks (collaborative relationships) among a diverse group of stakeholders.

Maintaining effective communication with the project team over time raises the quantity of social ties and the clustering co-efficient both directly and indirectly. This is consistent with Zhong and Low's (2009) findings that changes driven by the project management are usually unlikely to produce desired effects without coordination and support from a variety of personnel. Project managers however, are most times preoccupied with addressing the technical issues and fail on soft issues like proper functioning of informal communication. The value of oral

communication must be taken into consideration as it affects the interaction patterns among project members. In the current era of the internet, e-mail and instant messaging, the quality of the actual communication can determine the longevity of the group and help predict the likelihood of the group's survival. Face-to-face communication is needed, especially in the early stages, to establish understanding and trust among members. In order to understand further the relationship between project communication and social networks we therefore hypothesize that:

H1: Internal project communication and network degree are positively and significantly related.

H2: External project communication and network transitivity are positively and significantly related.

2.4 Social Networks and Perceived Project success: According to Hogg and Adamic (2004) Social networks act as a vehicle for quickly and easily getting the project message to intended audience thereby enhancing project awareness and the organization's public image at large. Similarly, Burt (2001) argues that Social networks provide access to timely information and referrals to others in the network. He adds that timely access to information among others creates a deeper understanding of community needs at initiation stage of any project development. This supports the view that ample information at initiation mitigates the possibility of losing out on quality in the later stages as a result of inadequate project planning. Particularly, collaborations create perceived fairness in exchanges there by reducing transaction cost (Hoang & Antoncic 2003) in form of less detailed contracts and less restrictive clauses with stakeholders like the government. Transactions involve cost of discovering who it is that one wishes to deal with, informing people that one wishes to deal and on what terms, conducting of negotiations among others which is cheaply and quickly achieved through social networks. Therefore the following hypotheses are proposed for examination:

H3: Network degree is positively and significantly related to perceived project success

H4: Network transitivity is positively and significantly related to perceived project success

2.5 In order to investigate the mediating effect of social networks that may be exists between project communication and perceived project success, the following hypotheses are proposed. However, whether this mediation effect is full or partial warrants more examination. We therefore hypothesize that;

H5: Network degree significantly mediates the relationship between internal project communication and perceived project success.

H6: Network transitivity significantly mediates the relationship between external project communication and perceived project success.

Figure 1 shows the research model with the hypothesised relationships between project communication strategies, social network dimensions (network degree and network transitivity) and perceived project success.

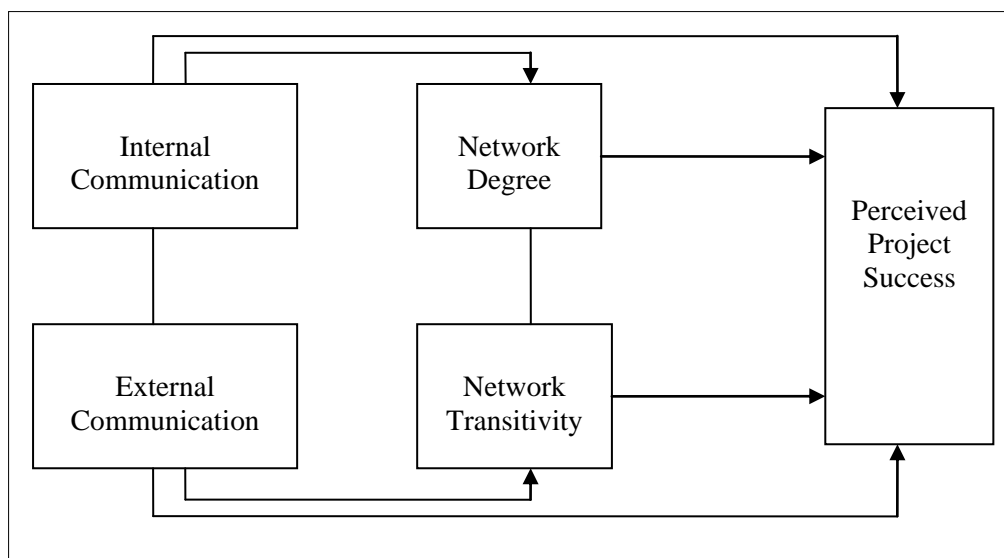

Figure 1: Research model

3.0 METHODOLOGY AND RESEARCH APPROACH

3.1 operationalization of study constructs: For practical purposes, Project communication was categorised as internal project communication and external project communication and measured using Goldhaber and Rogers' (1979) Communication Audit Survey (CAS) questionnaire. Respondents assessed project communication survey items on a five (5)-point Likert scale ranging from 1=Strongly Disagree, 2=Disagree, 3=Not Sure, 4=Agree and 5=Strongly Agree. Social networks were measured using a combination of the network Degree and network transitivity (Fowler et al., 2009; Rosenthal, 2007, P.293). Respondents assessed their perceived network position on a five (5)-point Likert scale ranging from 1=Strongly Disagree, 2=Disagree, 3=Not Sure, 4=Agree and 5=Strongly Agree. Perceived Project success was measured using an amalgamation of the research measures used by Pinto and Slevin (1988) and Shenhar et al. (1997) and the competence areas defined in the Project Management Body of Knowledge (PMBOK, 2008). The responses were also anchored on a 5 linkert scale ranging from 1=Strongly Disagree, 2=Disagree, 3=Not Sure, 4=Agree to 5=Strongly Agree.

3.2 Sampling procedure, pilot testing, refinement and survey responses: A census of all 121 philanthropic projects conducted by all 24 commercial banks in Uganda with at least a market share above 1% were examined (Bank of Uganda, 2009). This is because investments in philanthropic projects in Uganda are commonly undertaken by commercial banks with a market share of not less than 1%. The unit of inquiry comprised the project workers who were knowledgeable or had ever taken part in the philanthropic projects. Firstly, the self-administered questionnaire was first pre-tested on professors from Makerere University Kampala, a major research university in Uganda. They had all had worked on philanthropic projects in Africa for a remarkable time of more than four years with a wide experience on this topic. The measurement scales were also pilot-tested using 45 philanthropic projects and yielded 100% response rate. Based on these responses and comments, item scales that were unclear and ambiguous were either improved or deleted. Following the guidelines set forth by Dillman (1991) questions were brief and to the point, addressing only a single issue at a time and avoided phrases that could elicit socially acceptable response. Each construct was measured by at least three questions that were relevant in terms of prior research or established theory. A well-designed cover letter was included that explained the purpose and intended use of survey data and promised anonymity of respondent and company in the reporting.

4.0 RESULTS FROM DATA ANALYSIS

Out of 392 questionnaires that were initially sent out, 322 usable questionnaires were received back representing 82% response rate which were analysed and the descriptive statistics demonstrated that 54% of respondents had been involved in the execution of philanthropic projects for a period of 3-6 years. 6.4% and 1.7% had spent 7-10 and more than 10 years respectively in the execution of philanthropic projects. The findings further indicated that most of these projects have existed for about 3-6 years (48.8%), less than 3 years (43.6%) and more than 10 years (2.9%). The majority of respondents were females (51.7%) and (48.3%) were males which could imply that more females take up philanthropic activities than their male counterparts. Majority of these respondents were either married (52%) or single (46%) with majority in the age bracket of (20-30) years representing 73.3%. 72.7% of the respondents had attained at least a bachelor's degree, 4% and 15% had masters and professional qualifications respectively. The project types included health (31.7%), education (19%), environment (11.1%), economic (25.4%) and rehabilitation (12.7%). As regards the positions held in the execution of philanthropic projects by individual respondents, majority (78.5%) of them revealed that they held the capacity of team members while 10.5% were project managers and 4.1% were project beneficiaries.

4.1 Correlation and Regression analyses

In order to test the relationships that exist between the predictor, mediating and dependent variables, Pearson's bivariate coefficient was used. Based on results in Table 1, 2 and 3, survey data supported all the six (6) hypotheses. The results in Table 1 reveal that internal project communication has positive and significant relationship with network degree ($r=0.66, p<0.01$) hence supporting *H1: Internal project communication and network degree are positively and significantly related*. There was a strong and significant association between external project communication and network transitivity ($r=.655, p<0.01$) hence supporting *H2: External project communication and network transitivity are positively and significantly related*.

Table 1: Zero order correlations between project communication strategies, social networks dimensions and perceived project success

	Mean	SD	1	2	3	4	5
Internal project communication(1)	3.89	.692	1.00				
External project communication(2)	3.75	.650	.693**	1.00			
Network Transitivity(3)	3.91	.639	.722**	.655**	1.00		
Network Degree(4)	3.79	.787	0.66**	.625**	.788**	1.00	
Perceived Project Success(5)	3.77	.621	.727**	.735**	.813	.810	1.00

Note: Correlation is significant at less than 0.01 (2-tailed).

There was also a strong and significant positive association between network degree ($r=0.810$, $p<0.01$), network transitivity ($r=.813$, $p<0.01$) and perceived project success hence supporting both *H3: Network degree is positively and significantly related to perceived project success* and *H4: Network transitivity is positively and significantly related to perceived project success*. Other findings reveal that internal project communication ($r=0.727$, $p<0.01$) and external project communication ($r=0.735$, $p<0.01$) are positively and significantly correlated to perceived project success.

4.2 Testing for mediation effects

Consistent with Baron and Kenny's (1986) four conditions for existence of mediation effects were tested and results are summarized in Table 2 and 3. Firstly, the mediation effect of network degree between project communication and perceived project success was tested. Table 2 indicates that all the four conditions for mediation effects are met according to Baron and Kenny (1986).

Firstly, there is an effect to be mediated ($\beta=0.619$, $p<0.01$). Secondly, there is a significant relationship between internal project communication and mediator (network degree) ($\beta=0.612$, $p<0.01$), and third, the coefficient of the mediator (i.e. network degree) is significant in regression model three ($\beta=0.444$, $p<0.01$) with both internal project communication and mediator (network degree) as predictors. Similarly, the total effect of internal project communication on perceived project success is less in regression three (*standardized Beta coefficient*= 0.333, $p>0.01$) than in regression model two (*standardized Beta coefficient* =0.727, $p>0.01$). Hence providing support for *H5: Network degree significantly mediates the relationship between internal project communication and perceived project success*. Since the coefficient of the predictor is other than zero, then these findings indicate that partial mediation exists in this relationship.

Table 2: Mediating effect of network degree on the relationship between internal project communication and perceived project success

Predictor	Dependent variable								
	Network Degree			Perceived project success					
	Model 1			Model 2			Model 3		
B	SE	Beta	B	SE	Beta	B	SE	Beta	
Intercept	1.489	.151		1.401	.201		1.032	.163	
Internal communication	.612**	.039	.655	.619**	.052	.727	.283**	0.54	.333
Network Degree							.444**	.048	.587

*Note: N=322, * $p<0.05$, ** $p<0.01$*

Further, the mediation effect of network transitivity between project communication and perceived project success was also tested. Table 3 shows that all the four conditions for existence of mediation effects are also met according to Baron and Kenny (1986). First and foremost, there is an effect to be mediated ($\beta=0.674, p<0.01$). Secondly, there is a significant relationship between external project communication and mediator (network transitivity) ($\beta=0.610, p<0.01$), and third, the coefficient of the mediator (i.e. network degree) is significant in regression model three ($\beta=0.569, p<0.01$) with both external project communication and mediator (network transitivity) as predictors. Similarly, the absolute effect of external project communication on perceived project success is less in regression three (*standardized Beta coefficient* = 0.347, $p>0.01$) than in regression model two (*standardized Beta coefficient* = 0.737, $p>0.01$). Hence supporting that *H6: Network transitivity significantly mediates the relationship between external project communication and perceived project success*. Since the coefficient of the predictor is also not zero, then these findings also indicate that partial mediation exists in this relationship.

Table 3: Mediating effect of network transitivity on the relationship between external project communication and perceived project success

Predictor	Dependent variable								
	Network Transitivity			Perceived project success					
	Model 1			Model 2			Model 3		
	B	SE	Beta	B	SE	Beta	B	SE	Beta
Intercept	1.489	.151		1.276	.207		.376	.186	
External communication	.610**	.039	.810	.674**	.055	.735	.318**	.057	.347
Network Transitivity							.569**	.061	.582

*Note: N=322, * $p<0.05$, ** $p<0.01$*

5.0 DISCUSSION OF FINDINGS

The purpose of this study was to examine the mediating effects of social networks dimensions of network degree and network transitivity on the relationship between project communication strategies and perceived project success. We initially hypothesised that internal project communication and external project communication which are considered as two most prominent strategies of communication, affect perceived project success through the mediation of social network dimensions of network degree and network transitivity. As hypothesised, our results reveal that these two mediating effects between project communication strategies and perceived project success were significant. Thus, the research model depicted in Figure 1 is fully supported.

The results further revealed that internal project and external project Communication are both positively associated with social network dimensions of network degree and network transitivity and indicated that network degree and network transitivity are both positively related to perceived project success. This indicates that where project managers listen to other stakeholders and incorporate their views in the decisions they implement, over time, many stakeholders are likely to be propelled to act as the bank's advocates and may be depended on by the bank as marketing agents (Nangoli, 2010; Ahimbisibwe & Nangoli, 2012a). These findings are in agreement with those of Granovater (1973) and Herkt (2007) who showed that reinforced relationships overtime become dependable. Furthermore, the findings support the fact that Project communication determines the extent to which a particular project wins the collective support and efforts of team members which is in line with Cooke-Davies (2002), Jugdvev and Muller (2005) and Ahimbisibwe & Nangoli (2012b).

In addition, the results also imply that efforts to promote effective communications through availing timely information to stakeholders leads to strengthening of the relationships that exist amongst stakeholders. The results are in agreement with Rasbery and Lamoine (1986) who argued that the consideration of the recipient's preferences in terms of time and means of communication bring about building of trust amongst the two parties. These findings also implied that when the societies within which a commercial bank operates are in support of its citizenship projects, the bank incurs lower cost on implementation of such projects (Ahimbisibwe & Nangoli,

2012a). This could be in terms of the locals availing some free labour during implementation. It could be in form of having locals actively pass on the information to other locals at no cost. These findings are in agreement with those of Hogg and Adamic (2004) and Ahimbisibwe & Nangoli, (2012b) who concur that social networks act as a vehicle for quickly and easily getting the project message to intended audience thereby enhancing awareness and the banks' public image at large. The findings also revealed that Social networks provide the shared maintenance necessary to calm down high stress levels and enable achievement of not only timely but quality outputs. These findings also reflect studies by Pinto (2000) who argued that there is a need to develop a network of other experts who can be called upon for assistance.

These findings further indicate that project communication does not directly influence perceived project success. This means that project communication must work through social networks in order to achieve significant influence on project success. This study therefore makes a significant contribution by empirically concluding that social networks partially mediate the relationship between project communication and perceived project performance. This means that projects need social networks to achieve their goals successfully in addition to project communication.

6.0 PRACTICAL AND THEORETICAL IMPLICATIONS

There is a need for all philanthropic project managers, investing banks and champions to ensure that other project stakeholders have been provided with and are satisfied with the availed project information, this will enable the both financial and non-financial resources that are invested into philanthropic projects to be successful. Similarly, where project supervisors are not as attentive to their subordinates' views and no appropriate avenues have been designated to capture feedback from implementers' and beneficiaries of the project, there will be a high chance of failure of philanthropic projects. The project managers in charge of philanthropic projects in commercial banks ought to ensure commitment of project staff to achievement of objects by creating an atmosphere of feeling like they (project staff) are part of the family of the project implementation team by involving them in communication. There is a need to fulfil the promises that top management sets forth. In this way, the various stakeholders involved in implementation are likely to perceive the project as a success. This study has extended the research borderlines in understanding the mediating effect of social network dimensions of network degree and network transitivity on the relationship between project communication strategies and perceived project success. This is an important contribution towards understanding the relationship between these study variables to create a meaningful interpretation of findings; thereby making it easy for project managers and researchers to make correct conclusions and implications for project success.

7.0 LIMITATIONS, DIRECTIONS FOR FUTURE RESEARCH AND CONCLUSION

Despite this research providing some exciting findings and making an important contribution in understanding the mediating role of social networks dimensions of network degree and network transitivity between project communication strategies and perceived project success, it has the following limitations. Firstly, the use of a questionnaire where all the data was collected in the same measurement context using a common rater and with common item context makes common methods bias remain a potential threat. The future studies should try to obtain measurements of the independent and dependent variables from different sources and at different times. Secondly, the study used a cross sectional research design implying that variables over a long time could not be completely analysed and this restricts the applicability of the findings as a longitudinal study may give different results from the ones that were obtained. Future research should use longitudinal data and a bigger sample involving other stakeholders like the regulators, customers, local population, among others. This is because the accommodation of various stakeholders could give a different view. Also, the data collection instrument used was a standard questionnaire which usually limits the ability to collect views about information outside asked question. The use of case studies and additional surveys in future research might help to give more explanation. Further, although the three constructs are robust and adequately characterize the 'soft' factors, the multidimensional nature of behavioural practises in perceived project success can be investigated further.

In conclusion therefore, the findings reveal that social network dimensions of network degree and network transitivity partially mediate the relationship between project communication strategies and perceived project success. This implies that managers of philanthropic projects need to develop strategies to create social networks with their stakeholders in order to increase perceived project success. Both internal and external communication strategies significantly influence social networks hence the need to pay attention to project communication strategies to achieve social networks that lead to perceived project success.

REFERENCES

- Ahimbisibwe, A., & Nangoli, S. (2012a). Project Communication, Individual Commitment, Social Networks, and Perceived Project Performance. *Journal of African Business*, 13 (2):101-114
- Ahimbisibwe, A., & Nangoli, S. (2012b). Using the Behavioural Factors to explain Perceived Project Performance of Ugandan Citizenship Projects: A Multivariate Analysis. *International Journal of Business and Social Science*, 3 (10):208-224.
- Andrews, R. (2007). Organizational Social Capital and Public Service Performance. Presentation at the 9th Public Management Research Conference, University Of Arizona, Tucson, USA.
- Bank of Uganda. (2009/2010). Annual report. Retrieved on September 14th, 2012 from http://www.bou.or.ug/export/sites/default/bou/boudownloads/publications/Annual_Reports/Rpts/All/annualReport2009-10.pdf
- Barclays Bank Uganda. (2007). Sustainability review report. Retrieved on September 14th, 2012 from <http://group.barclays.com/about-barclays/investor-relations/financial-results-and-publications/annual-reports>.
- Burt, R.S. (2001). *Bandwidth and Echo: Trust, Information and Gossip in Social networks*. Integrating the Study of Networks and Markets, New York: Russell Sage Foundation.
- Cavana, R.Y., Delahaye, B.L., & Sekaran, U. (2001). *Applied Business Research: Qualitative and Quantitative Methods*. Brisbane: John Willey & Sons.
- Cockburn, A., & Highsmith, J. (2001). Agile Software Development: The People Factor. *Computer*, 34 (11), 131-133.
- Cooke-Davies, T. (2002). The "Real" Success Factors on Projects. *International Journal of Project Management*, 20 (3), 185-190.
- Crawford, L., & Pollack, J. (2003). Hard and Soft Projects: A Framework for Analysis. *International Journal of Project Management*, 22, 645-653
- Dickerson, C.A., Thibodeau, E.A. & Miller, D. (1992). Using Cognitive Dissonance to encourage Water Conservation, *Journal of Applied Social Psychology* 22 (11): 841-854.
- Dillman, D. A. (1991). The Design and Administration of Mail surveys. *Annual Review of Sociology* 17, 225-248
- Downes, S. (2005). Semantic Networks and Social Networks. *The Learning Organization*, 12 (5), 11-417
- Drucker, P.F. (1993). *Post-Capitalist Society*, Butterworth-Heinemann, Oxford.
- Eemeren, F.H. V, Grootendorst, R. & Snoeck Henkemans, F. et al. (1996). Fundamentals of Argumentation Theory. A Handbook of Historical Backgrounds and Contemporary Developments. Mahwah, NJ: Erlbaum.
- Fowler, J., Dawes, C., & Christakis, N. (2009). Model of Genetic Variation in Human Social Networks. *Annual Review of Sociology*, 106(6), 1720-1724
- Granovetter, M., S. (1973). The Strength of Weak Ties. *American Journal of Sociology* 78(6), 1360- 1380.
- Goldhaber, G., & Rogers, D. P. (1979). Auditing organizational communication systems: The ICA communication audit. Dubuque: Brown Publishers.
- Heath, R.L. & Bryant, J. (2000). *Human Communication Theory and Research*. Concept, Context and Challenges. Mahwah, NJ: Erlbaum.
- Herkt, M. (2007), "What is in It For Us?" *PM Network*, 21 (3).
- Hoang, A. & Antoncic, B. (2003). Network-Based Research in Entrepreneurship: A Critical Review. *Journal of Business Venturing*, 18(2), 165-87.
- Hogg, T. & Adamic, L. (2004). Enhancing Reputation Mechanisms Via Online Social Networks. *Proceedings of the 5th ACM Conference on Electronic Commerce*, EC'04, ACM Press, New York, NY.
- Hopkins, M. (2007). *Corporate Social Responsibility & International Development*. London: Earthscan.
- Howell, D., Windahl, C., & Seidel, R. (2010). A Project Contingency Framework Based on Uncertainty and its Consequences. *International Journal of Project Management*, 28 (3), 256-264.
- Jugdvev, K., & Muller, R. (2005). A Retrospective Look at our Understanding of Project Success. *Project Management Journal*, 36 (4), 19-31.
- McDonald, M. L., & Rundle-Thiele, S. (2008). Corporate Social Responsibility and Bank Customer Satisfaction. *International Journal of Bank Marketing*, 26(3), 170-182.
- Nangoli, S., (2010). *Project Communication, Individual Commitment, Social Networks and Perceived Project Performance*. Unpublished Master thesis report: Graduate Research Centre, Makerere University Business School.
- Ntayi, J. M., Rooks, G., Eyaa, S. & Qian, C. (2010). Percieved Project Value, Opportunistic Behaviour, Interorganisational Cooperation, and contractor Performance. *Journal of African Business* 11(1), 124-141.

- Petty, R.E. & Cacioppo, J.T. (1986). *The Elaboration Likelihood Model of Persuasion*. New York: Academic Press.
- Pinto, J.K. (2000). Understanding the Role of Politics in Successful Project Management. *International Journal of Project Management*, 18, 85-91.
- Pinto, J. K., & Slevin, D. P. (1988). Critical Success Factors across the Project Life Cycle. *Project Management Journal*, 19(3), 67-75.
- PMI. (2008). *A Guide to the Project Management Body of Knowledge (PMBOK Guide)* (4th ed.). Project Management Institute.
- Ramsing, L. (2009). Project Communication in a Strategic Internal Perspective. *Corporate Communications: An International Journal* 14 (3), 345-357
- Rasberry, R.W. & Lemoine, L.F. (1986). *Effective Managerial Communication*. PWS-KENT Publishing Company Boston, Massachusetts.
- Rosenthal, E. (2007). Social Networks and Team Performance. *Team Performance Management journal*, 3(4), 288-294.
- Ruuska, K. (1996). Project Communication. World Congress on Project Management (pp. 67–76), IPMA 96, Paris, France. Retrieved on September 14th, 2012 from http://cms.3rdgen.info/3rdgen_sites/107/resource/Soft%20Skills%20in%20PM.pdf
- Sauser, B. J., Reilly, R. R., & Shenhar, A. J. (2009). Why Projects Fail? How Contingency Theory Can Provide New Insights - A Comparative Analysis of NASA's Mars Climate Orbiter Loss. *International Journal of Project Management*, 27 (7), 665-679.
- Scott, J. (2000). *Social Network Analysis: A handbook*. Second edition. London: Sage.
- Scott, S. (2007). Corporate Social Responsibility and the Fetter of Profitability. *Social Responsibility Journal*, 3(4), 31-39
- Shenhar, A. J., Tishler, A., Dvir, D., Lipovetsky, S., & Lechler, T. (2002). Refining the Search for Project Success Factors: A Multivariate, Typological Approach. *R&D Management*, 32 (2), 111-126.
- Wateridge, J. (1999). The Role of Configuration Management in the Development and Management of Information Systems/Technology (IS/IT) Projects. *International Journal of Project Management*, 17(4), 237-41
- Yeo, K.T. (2002). Critical Failure Factors in Information System Projects. *International Journal of Project Management*, 20(3), 241-6
- Zhong, Y., & Low, S. P. (2009). Managing Crisis Response Communication in Construction Projects: From a Complexity Perspective. *Disaster Prevention and Management*, 18(3), 270–282.