

A review on maximum power point tracking for photovoltaic systems with and without shading conditions



Makbul A.M. Ramli ^{a,*}, Ssennoga Twaha ^b, Kashif Ishaque ^c, Yusuf A. Al-Turki ^a

^a Department of Electrical and Computer Engineering, King Abdulaziz University, Jeddah 21589, Saudi Arabia

^b Energy and Sustainability Division, Faculty of Engineering, University of Nottingham, NG7 2RD United Kingdom

^c Department of Electrical Engineering, Mohammad Ali Jinnah University, Karachi 75400, Pakistan

ARTICLE INFO

Article history:

Received 1 January 2015

Received in revised form

26 May 2016

Accepted 6 September 2016

Keywords:

Photovoltaic system

Maximum power point tracking

Normal condition

Partial shading condition

ABSTRACT

This paper discusses maximum power point tracking (MPPT) methods of PV system for normal and partial shading conditions (PSC). The selected MPPT methods were classified as artificial intelligent, hybrid, and other MPPT methods. The comparison of researches on MPPT methods under normal condition and PSC reveals that researchers have concentrated more on shading conditions since the last few years mainly due to the need of power output and efficiency improvements. It is believed that the information contained in this piece of work will be of great use for the researchers in the field under consideration.

© 2016 Elsevier Ltd. All rights reserved.

Contents

1. Introduction	144
2. Solar PV parameterization	146
3. MPPT of PV systems without partial shading	146
3.1. Artificial intelligent methods for MPPT under uniform insolation	146
3.2. Intelligent MPPT with reconfigurable field programmable gate array (FPGA) technology	146
3.3. Hybrid methods used for MPPT of PV system under normal insolation	147
3.4. Other MPPT methods under normal insolation	147
3.5. Converter configuration used for MPPT treatment	148
4. Partial shading condition	149
5. MPPT for partial shading treatment	150
5.1. Artificial intelligent techniques for MPPT under PSC	150
5.2. Evolutionary programming techniques for MPPT under PSC	150
5.3. Hybrid methods with conventional and artificial intelligence algorithms for MPPT of partially shaded PV systems	152
5.4. Other MPPT methods under PSC	154
6. Conclusion	156
Acknowledgment	156
References	156

1. Introduction

Among the renewable energy resources, solar PV is the most

common application in the world. Fluctuation of weather conditions and PSC are proved to be the popular problems for PV systems rendering them yielding lower power output. Therefore, enhanced operation of PV is required to extract maximum power under these conditions [1]. Statistic and Parallel Testing Procedures have been laid for effective evaluation of the MPPT

* Corresponding author.

E-mail address: mramli@kau.edu.sa (M.A.M. Ramli).

algorithms of PV Systems [2]. Low-power energy harvesting systems have also been designed with better MPPT techniques to improve the power output of PV systems [3]. Likewise, the power output of partially shaded PV systems can also be maximized using optimization of the interconnections of its modules [4]. Efficient energy harvesting and MPPT is also possible with the use of electromagnetic energy transducers and active low-voltage rectification [5]. This ensures improved power levels and wide supply voltage ranges especially in wireless sensor nodes such as those applied in medical implants. Another approach to enhance the power output of the shaded PV array is to arrange the physical position of modules in totally cross tied configuration, without altering the electrical connection of the modules in the array, so that the power output of the PV system increases [6]. In addition, energy can be recovered from shaded PV modules by applying a simple energy recovery scheme during PSC [7]. Maximum utilization of power from PV systems is also ensured by employing energy storage systems that backup energy from the PV array. Such systems include a compressed air accumulator which is controlled to enable compression and expansion modes under maximum efficiency point tracking (MEPT) and at the same time an MPPT power converter is connected to the PV system [8].

Self-shading losses also affect the output power of the fixed PV array which is standing freely. The rows formed by the modules in PV arrays can also shade the rows of the module behind each other. Parameter modifications based on location-independent experimental equation for the module-to cell width ratio were used to determine the self-shading losses [9]. Fault diagnosis with distributed MPPT for PV systems is necessary especially at module level and micro-inverters. To address this matter, an approach to diagnose the PV systems faults was presented in [10]. The advantage of this method is that monitoring of the PV plant parameters such as voltage and current at the working power point is possible.

MPPT has been carried out on different PV system configurations. For stand-alone PV system configurations, an MPPT based three-point-weighting method and mid-point tracking was conducted [11]. An MPPT control method developed for stand-alone system was applied to a power conditioning system whereby the I-V characteristics are scanned with detection interval control at specified intervals. The effectiveness of this method was demonstrated for PSCs [12]. Another MPPT technique for stand-alone PV systems under PSC was introduced to ensure the achievement of the global MPP for varying PSC [13]. Performance enhancement of solar PV systems has been achieved by designing a novel MPPT algorithm that uses short circuit current and open circuit voltage, sampled from a reference solar PV system. The method was checked for its performance in local environmental conditions [14].

Some research directed towards the control strategies for the optimization of distributed MPPT in PV applications is also necessary for proper operation of PV systems [15]. Therefore, optimum MPPT Controllers for PV systems during PSC can for example be achieved with conventional proportional integral derivative (PID) and Fuzzy Logic (FL) [16]. A novel MPPT technique for PV modules based on power plane analysis of I-V characteristics was proposed. The power region in the I-V characteristics was determined by examining the effects of the characteristic resistances of the PV module [17].

Similarly, MPPT methods for grid connected PV systems have been analyzed such as the enhanced MPPT that uses voltage-oriented control, which has improved tracking capability under fast changes in irradiance [18]. Exact MPPT of grid-connected partially shaded PV systems was introduced using current compensation concept [19] while an FL based MPPT algorithm was tested for grid-connected PV system under PSC [20]. Furthermore, some MPPT methods for three-phase PV system have also been presented in

which a three-phase single-stage PV system with improved MPP tracker was tested with increased power rating [21].

A method designed for optimal arrangement of PV array with converterless matching to a given linear load revealed the difference between MPP matching and MPPT for solar generators. It was found out that for a pure resistive load, the PV system with MPPT has undoubted benefits. For a load represented by internal resistance and voltage source, the long term power output from the system using a practical MPPT operated converter is at the same level or even lower than a converterless system in term of power output [22]. In one study, the experimental investigation was carried out to assess the performance of a global MPPT and to analyze the effect of geometrical installation parameters of flexible PV modules, such as the tilt angle, bending angle and orientation, on the shape of the P-V characteristic [23]. The power loss during MPP search process was minimized whereas the output power for the flexible PV array was maximized.

MPPT techniques for PV systems have been classified and compared by some researchers [24–27]. For example, according to [25], conventional methods include incremental conductance (IC), perturb and observe (P&O), and hill climbing methods. The variant of these three methods have also been used in literature for MPPT of solar PV systems. A comparative study on MPPT techniques for PV systems available until January 2012 details the classification and description of MPPT techniques [28].

Intelligent methods and their hybrids have also been utilized to study MPPT of PV under both uniform and non-uniform irradiance. Intelligent techniques are sometimes referred to as soft computing (SC) techniques and are known to have the ability and flexibility to solve non-linear tasks and are suitable for handling different challenges arising out of adverse environmental conditions like rapid changes in irradiance and PSC [29]. It has also been observed that conventional control methods sometimes operate the PV system at local maxima. Hence, performance enhancement of PV array may be achieved with the aid of intelligent techniques especially under non-uniform irradiance conditions [30]. Partially shaded PV array have been optimized using Fuzzy MPPT which is inserted in conventional MPPT algorithms to adjust the size of the perturbed voltage [31]. Authors in [32] performed the analysis and comparison of stochastic and conventional MPPT methods based on the real MPP tracker ability, cost consideration, complexity of design, convergence speed and responsiveness to changing environmental conditions. Relatively, the artificial intelligence and stochastic algorithms show excellent tracking performance.

Laboratory prototype for the emulation of PV systems for both dynamic and PSC plays a significant role in determining the accuracy and efficiency of the proposed methods before they are practically implemented for commercial applications [33]. Experimental investigation of partial shading scenarios on different types of PVs such as mono-crystalline and poly-crystalline is paramount [34]. Software packages have also been developed that are being used to study the PV system performance under various conditions. For example, a CAD package for simulation and modeling of PV arrays under PSC is one of them [35].

The application of PV system in the buildings commonly known as building integrated PV (BIPV) is also very popular. Research directed towards this field to estimate the performance of PV arrays under PSC has intensified [36]. For instance, a novel MPPT algorithm combining the improved P&O and scanning technique to track the global MPP under PSC for BIPV was developed [37].

In this paper, a brief review of research work based on the study of PV parameters will be done followed by a compressive review of MPPT for PV systems under uniform insolation and PSC. The emphasis is given to the documentation of the latest research works on MPPT for PSC.

2. Solar PV parameterization

PV modeling is very important in studying the behavior and performance of different types of solar cell and to improve their efficiency. Investigation of the accuracy of PV modeling for non standard test conditions (STC) is also important to analyze the impact of inaccuracies of prediction for real operating conditions [38]. For these reasons, various researches have been done to analyze the PV parameters. A PV array model that uses PSpice proprietary electronic simulation software to represent all mismatch effects was developed in [39] to deal with non-uniform irradiance and other non-uniformities across the array. The model produces various I-V characteristics per simulation. Picault et al. presented a new method for forecasting the present PV system power output with changing atmospheric conditions where field measurement data was used to find the PV parameters [40]. A simple model to estimate PV arrays shading losses have also been presented and used directly to calculate the PV power, without consideration of a full current curve [41].

Another method based on a two-diode model, as depicted in Fig. 1, was proposed for accurate modeling of PV system under PSC [42]. This model requires only four parameters and is known to have better accuracy at low irradiance level, allowing for more accurate prediction of PV system performance during PSC.

Using this model, the cell output current is defined as

$$I = I_{PV} - I_{D1} + I_{D2} - \left(\frac{V + IR_s}{R_p} \right) \quad (1)$$

3. MPPT of PV systems without partial shading

In this section, artificial intelligence and hybrid methods are analyzed. Meanwhile, converter configurations suggested for using in PV systems are also discussed.

3.1. Artificial intelligent methods for MPPT under uniform insolation

Intelligent MPPT for PV systems was formulated by optimizing the Hopfield neural network (HNN) with a fuzzy logic controller (FLC). In this approach, HNN was used to tune the FLC membership functions automatically rather than the application of the trial-and-error method. It was verified that the optimization of HNN by FLC enabled PV tracking accuracy and improved efficiency of the PV system [43].

The MPPT controller using artificial neural network (ANN) algorithm for PV system applications was introduced in [44], as shown in Fig. 2. The ANN algorithm's accuracy was proved using different sets of data. The estimates from ANN tracker were used to regulate the duty cycle of the chopper to an optimum value required to achieve MPP at the specified load.

The comparison of NN and FL in MPPT for PV systems was done by authors in [45]. The method results in a good MPP of each type of PV array with various conditions such as varying temperature

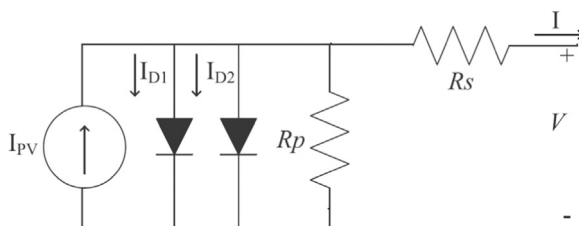

Fig. 1. Two-diode model of PV [42].

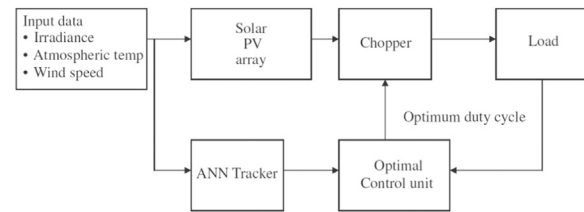

Fig. 2. MPPT controller using ANN algorithm [44].

and irradiance. The NN controller was observed to provide less power compared to the FL controller and therefore the FL controller can provide more power than MPPT methods.

Another variant of FL is the polar coordinated FL for real-time tracking of MPP for the PV system [46]. The approach utilizes FL and ANN controller by employing polar information. The Fuzzy rules were applied to operate the PV array at the maximum operating point while ANN were used to find the best operating voltage for triple junction amorphous silicon, monocrystalline silicon and thin-film cadmium telluride solar cells.

In [47], modeling of solar PV module and MPPT using adaptive neuro-fuzzy inference system (ANFIS) was carried out. The response of proposed ANFIS based control system showed high accuracy and fast response. The simulation result reveals that the MPP is tracked reasonably for varying temperature and irradiance of PV module. Direct search algorithm was applied to global MPPT scheme for PV systems and the results indicated that the approach is fast and robust [48].

A biological swarm chasing algorithm was proposed for MPPT in which the PV was treated as a particle while the moving target was the MPP. So, each PV module could follow up the MPP automatically [49]. If compared with a nominal P&O method, the efficiency of the proposed tracker was improved about 12.19% in transient.

3.2. Intelligent MPPT with reconfigurable field programmable gate array (FPGA) technology

The study of present status and future prospect of MPPT-based AI techniques for PV systems and their application into FPGA was performed in [50]. It was observed that the rapid advancement in programmable logic devices comprising of FPGAs provides an option to integrate these methods efficiently for real time implementations.

An intelligent MPPT for PV applications was introduced using FPGA chip where several intelligent techniques were used in tracking the MPPT and their possible implementations into a FPGA platform were compared [51]. The intelligent techniques investigated in that study include NN, GA, FL, and hybrid systems (e.g. neuro-fuzzy or ANFIS and FL optimized by GA). The techniques were observed to be effective in terms of accuracy, flexibility, quick response, simplicity of implementation and power consumption. Most of these methods were seen with rapid response and better tracking although FPGA controller showed the best performance when compared to the other techniques.

In another work [52], real time application of MPPT based on FPGA for PV Systems was simulated using P&O algorithm. It was designed using the very high-speed description language (VHDL) and implemented on Xilinx Virtex-II-Pro(xc2v1000-4fg456) FPGA. The major advantages associated with this MPPT algorithm are inexpensive, good velocity, easy implementation, good reliability and efficiency of 96%. Uninterestingly, with rapid changes in irradiance, the method is likely to fail to track the MPP. An MPPT method based on FPGA for PV array operating under PSC has been proposed [53]. This method is centered on sensing the current and voltage values of a capacitor connected to the PV array output

during charging times. Then, it compares instantaneous power values to maximum power, and estimates maximum power value and corresponding voltage value. Implementation of FPGA based MPPT Controller of PV system was done based on PV system output voltage [54]. It was indicated that the designed system has the capability to successfully extract the MPP when evaluated in sunny day and PSC.

Dounis et al. [55] proposed an adaptive neural control to improve the performance of conversion efficiency of PV systems. The partial derivative of the PV power with respect to the PV voltage is considered as the controlled variable. The basic aim was to improve the dynamic performance of the MPPT system by the learning capability of a single neuron using a fast online learning approach. The results revealed that single neuron based learning was sufficient enough to adequately track the maximum point and hence, it does not require any complicated NN topology.

3.3. Hybrid methods used for MPPT of PV system under normal insolation

Two high performance and simple MPPT algorithms were proposed in [56]. These algorithms are modified P&O and IC algorithms. These modified algorithms are capable of tracking MPP under fast changing atmospheric conditions with higher accuracy than the conventional methods. With these hybrid systems, the harvested power from PV array is increased and the MPPT algorithm efficiency is improved.

Murtaza et al. presented a variable size P&O MPPT with the use of FL and non-switching zone schemes for implementation of the perturbations of variable sizes to improve the steady-state and transient responses. A reduced fuzzy P&O algorithm at the MPP region was optimized for small variations and applied to reduce the oscillations and improve the power output during steady-state [57].

The performance of P&O and IC MPPT method under changing weather conditions was analyzed by Punitha et al. [58]. The work was conducted on European Efficiency Test, EN 50530, which is specifically devised for the dynamic performance of PV system. The study revealed that both techniques output nearly the same dynamic MPPT efficiency though the performance of IC method was found to be slightly better at 98.5% efficiency compared to 98.3% for P&O.

Experimental analysis was carried out to investigate the impact of the four common MPPT techniques for including IC and P&O employed like tracking step constant whereas improved FL and P&O based MPPT algorithms used as variable tracking step [59]. By employing four similar PV arrays with identical set of meteorological and technical conditions, the four techniques produced nearly the same energy output but with a small improvement for the enhanced P&O method. Coupled-inductor with interleaved boost converter based MPPT for PV was proposed based on NN and FL controllers. A feed forward MPPT arrangement was formulated using a fuzzy controller. The analysis showed that the FL has better tracking performance [60].

A hybrid method for MPPT in PV systems was proposed under uniform irradiance [61]. This technique combines the online and offline techniques purposely to determine the duty cycle for the converter in tracking the MPP. Radiation intensity and temperature were taken as the inputs of the system during offline for estimation of the approximate maximum power with the application of analytical equations developed for solar cell. Adaptive hybrid MPPT method based on adaptive perturbation size for a PV system was formulated [62]. It was proved that by employing this method, a better performance is achieved and the power delivered at steady state increases by a factor of 7.31% compared with conventional methods.

3.4. Other MPPT methods under normal insolation

A testing standard based MPPT algorithm was proposed in which ramp and step variations in irradiance were considered. The effect of converter losses on MPPT were monitored and it was observed that the effects are minor so long as these losses are not excessive [63]. An MMPT scheme for solar heating system was developed to minimize the power consumption. The MPPT control system was verified to be able to reduce the energy consumption with optimal solar heat collection [64].

A fast and energy efficient MPPT circuit was implemented based on successive approximation register in an 800- μ W PV energy harvester prototype consisting of analog-based circuits [65]. The tracking time was decreased by 69.4% whereas energy stored was raised by 31.4% when compared with the hill climbing method for indoor conditions.

A sliding mode control strategy was employed for MPPT with high tracking efficiency [66]. The fast dynamics and stability are achieved by a sliding mode control and high tracking efficiency is attained by MPPT algorithm with fine step. A stable convergence across the PV curve was demonstrated from short-circuit to open-circuit.

An adaptive control design for MPPT in PV systems was introduced to deliver the maximum available power to the load under changes of solar insolation and ambient temperature [67]. The method was developed with two control levels; ripple correlation control (RCC) and model reference adaptive control (MRAC). By decoupling the two control algorithms, the system achieves MPPT with complete system stability. Results proved that the control algorithm allows the system to converge to the MPP in milliseconds.

A variable scaling factor based MPPT control technique was designed for PV system [68]. The developed MPPT technique determines the MPPT loop gain changes with regard to the operating point of the PV and the MPP is tracked based on nonlinear PV array output characteristics.

A rapid MPPT algorithm of PV systems was analyzed in which an early estimate of MPP is attained with the use of a variable step-size [69]. The robustness of the algorithm in the tracking of a transitional variable does not have a near association with the duty cycle. Another dynamic and rapid method used for MPPT uses the ripple correlation control. The method uses the significance of the signal ripple present normally in power converters which is understood as a perturbation through which the optimization of gradient ascent is achieved with a simplified circuit [70].

A real time optimization digital method called discrete time ripple correlation control (RCC) was applied to MPPT for PV system [71]. This digital technique is more flexible, less expensive and known its robustness than analog techniques. Applying simple modifications can make the RCC technique an abridged sampling problem i.e. if the suitable variables are sampled at the right times, MPPT algorithm can quickly get the MPP.

Geometrical prediction of MPP for PV array is another method worth mentioning. The method estimates the MPP parameters with high accuracy for any kind of PV technologies with different environmental conditions. This method is also suggested to act as a guide line to construct control scheme for real-time MPPT tracking in the PV system [72].

Time-domain array-reconfiguration (TDAR) based MPPT for solar cell arrays was presented that considers two-dimensional PV cells array to a single string of PV Cells which are more relevant for portable applications. It is suggested that the reduced complexity of the TDAR method renders it a scalable approach that can be applied to array reconfiguration in portable systems such as phones and laptops [73].

In [74], the authors brought two aspects while tracking the

MPP in PV system; to precisely discover the position of the MPP by means of the centered differentiation and to decrease the oscillation near the MPP in steady through the control of active perturbations. The steepest descent method is also adopted for smoother steady state and quicker dynamic response unlike the hill climbing technique.

A classical root-finding method was analyzed for application to digital MPPT for sustainable PV system. The method was found out to be faster in convergence to the MPP, conclusion drawn based on practical perspective and theoretical analysis to support the observations [75]. The feasibility of parabolic prediction to MPPT for PV array was consolidated after carrying out the performance evaluation of the approach under different atmospheric conditions [76]. Highly efficient and compact analog MPPT have also been studied for the PV system [77]. Combined with other MPPT methods, this approach is accurate and fast in tracking performance and has the capability to be incorporated to grid-connected inverter to supply ac power.

A modified differential evolution (DE) algorithm was used for MPPT of PV system in [78]. The standard DE was modified to deal with dynamic objective function problem to correspond with the nonlinear time-varying MPPT nature. The performance of the algorithm was evaluated under large and rapid fluctuations of irradiation and results indicated that this approach ensures faster and accurate convergence to MPP.

In [79], a nonlinear relation between environmental parameters (temperature and insolation) and the PV voltage at MPP is proposed. It is found that the voltage at MPP is robust to irradiance in a certain range, and this directs the choices of irradiance in experiments. Using this relationship, various MPPT control rules have been devised to track the MPP in a minimum possible time.

A sliding mode control (SMC) strategy is proposed in [80] to harvest the maximum energy from PV array, featuring fast tracking speed and reduced oscillation at steady state. Unlike the conventional schemes, which require both voltage and current as a feedback signal, this method only requires current signal to generate control actions. The obtained results were shown to exhibit faster tracking speed and up to 5% more MPPT efficiency can be achieved to that of conventional P&O.

Another SMC method is proposed in [81]. The control strategy is based on the admittance of the PV module to follow a reference provided by an external MPPT algorithm. Their proposed method also mitigates the perturbations generated by the load. The SMC is mathematically analyzed, and a design process is proposed to ensure the desired performance in all the operation range. The flowchart of their proposed SMC is given in Fig. 3.

3.5. Converter configuration used for MPPT treatment

A battery-integrated boost converter using distributed MPPT configuration for PV systems was introduced where the MPPT is unaffected by input power from PV load demand notably because of the use of battery and the proposed topology [82]. Conventional interleaved boost converter with implantation of two different topologies have been used for MPPT with IC method [83].

Single stage low cost micro-inverter with MPPT for grid connected schemes was developed with a new modulation and control technique [84]. The step time response of the system was enhanced by employing double analog control loops: a voltage loop and a hysteresis current mode control loop on the input voltage of the solar panel. A power loop for MPPT was introduced purposely for maximum power extraction from the solar panel with improved simulation times.

Current source inverter in place of voltage source inverter was used for MPPT during system prototyping and evaluation. The experimental results confirmed that the total output power

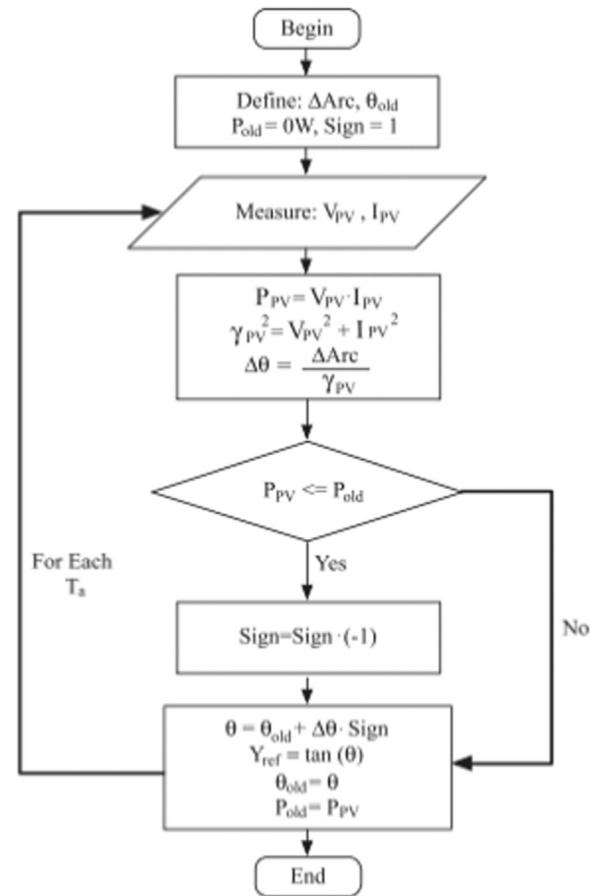

Fig. 3. The flowchart of the proposed SMC method [81].

captured the sum of each maximum value of PV under PSC [85].

An MPPT control strategy with variable weather parameter and non-DC/DC converter for PV systems known as inductance-capacitor-diode (LCD) was presented [86]. Using LCD in place of a DC/DC converter ensured that the MPPT performance is not influenced by the choice of DC/DC converter topologies and the PV configuration is simplified. A switched capacitor based boost converter structure was also used for a non-conventional MPPT method which has the capacity for tracking the absolute MPP of the PV system [87].

Current sensorless MPPT methods for PV module integrated converter was modeled using Zigbee wireless network [88]. This approach enables MPP tracking with the use of voltage information from the converter output in place of PV power calculation. This greatly simplifies the sensor network by eliminating the current sensor. Also important to note, by using central inverters, the most efficient connection scheme with PSC was developed based on the PV system operating conditions [89].

Unlike in the popular converter configurations such as string, micro and central converter for PV systems, different converter configurations were used in [90] for analysis of the impact of shading and bypass diode on energy extraction of PV arrays. It was established that the central converter PV systems with large-scale distributed bypass diode connections can act as an economic solution to improve PV system reliability, efficiency and performance especially in large scale utility PV generators unlike micro-converters.

An interleaved dual boost (IDB) converter instead of a conventional boost converter was used for matching the load to the PV system and to track the MPP for the solar cell [91]. The effectiveness of load voltage for tracking was confirmed and the results

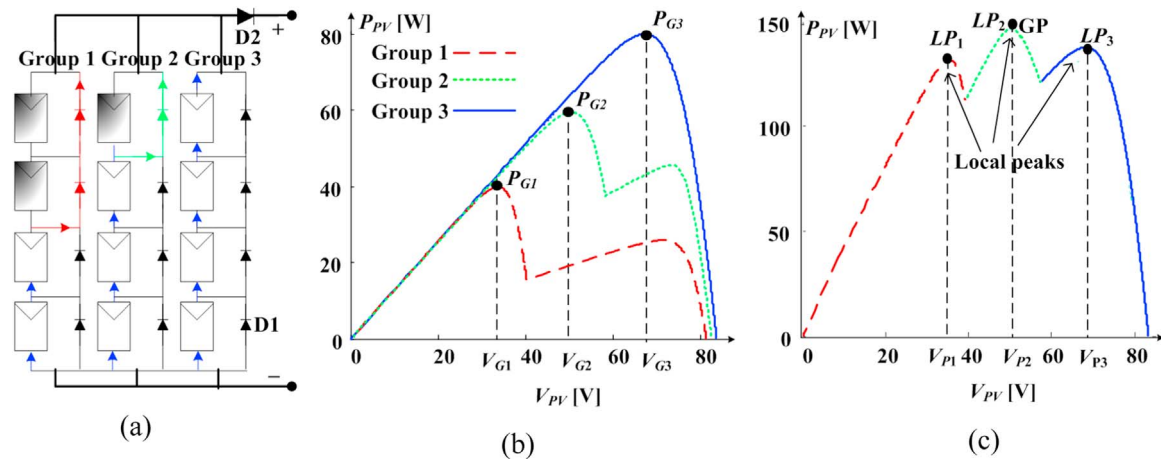

Fig. 4. (a) PV array configuration under PSC (D1 = bypass diode, D2 = blocking diode). (b) P–V curves of each group. (c) The P–V curve of whole array [102].

revealed that IDB converter is capable of reducing the ripple content in both source and load sides and therefore IDB converter based PV systems need small values of array input capacitance. Voltage-based MPPT control of PV system are incorporated with current sensorless peak power tracking to ensure tracking effectiveness [92].

Coupled inductor interleaved boost (CIIB) converter based MPPT for PV system were developed that uses load voltage information to eliminate the array current detection [93]. Unlike the non-coupled two-all interleaved converters, CIIB converter has low ripple content both on the load and source side, reduced switch stress and improved efficiency.

Multi-stacked buck-boost converters that make use of a single-switch voltage equalizer was proposed to deal with partial-shading issues of PV modules [94]. The use of single-switch topology ensures a simplified circuitry unlike the conventional equalizers that require multiple switches depending on the amount of PV modules/substrings.

A fourth-order buck converter is also one of the converters used for MPPT applications [95]. It was noted that the switch-mode dc-dc converters and the buck topology with an input L-C filter are popularly used for MPPT applications that have insufficient damping and therefore may show undesirable oscillations or operate at suboptimal power points for some solar insolation. Hence, fourth order buck converters are employed to eliminate this problem.

Flyback configuration based micro-inverter with distributed MPPT is also used for partially shaded PV module and energy recovery scheme. Proper tracking of MPP is achieved by incorporating a novel equalization circuit across the module that is also capable of energy recovery from the primary side leakage inductance, when the main switch is turned off [96].

Switched capacitor dc-dc converter based current equalization scheme for maximum power extraction from PV modules also operates without bypass diodes [97]. Though the bypass diodes are used for preventing the series connected PV modules from being damaged, for PV under PSC, they lead to completely loose power out of the shaded modules. Maximum power extraction from a PV array under PSC is also possible with shunt series compensation [98]. The method involves respective compensation of modules and strings with shunt (current) and series (voltage) compensators.

In another development, a one-cycle controller for the single stage inverter was designed for PV system. The design was made with the aid of a multi-objective strategy that optimizes the performance of the inverter at low and high insolation levels [99]. Useful information is also obtained from the optimization

algorithm, regarding the sensitivity of the system to every controller parameter and this permits the design of an MPPT P&O controller that meaningfully improves the inverter performance.

A boost-half-bridge micro inverter designed for grid-connected PV system was also designed using MPPT tracking and repetitive current control [100]. The converter uses minimal devices and was applied to achieve easy control, low cost, high reliability and high efficiency.

In [101], a new two-loop control strategy for a particular system was presented where bidirectional Cuk dc-dc converters were placed as bypass converters and a terminal Cuk boost operates as the entire system power conditioner. The proposed system was proved to have the ability to increase generated power of about 30% when compared with the conventional bypass diode structure.

4. Partial shading condition

It is always necessary to access the impact of PSC on the PV system so as to identify the correct solution. The impact of shading on a PV array is illustrated in Fig. 4.

Fig. 4(a) shows a configuration of series-parallel PV array operated under PSC. As group 1 and 2 modules are subjected to shading, they receive lower insolation. As a result, group 1 and 2 are characterized by two global peaks, P_{G1} and P_{G2} , which are lower than global peak of group 3, P_{G3} (Fig. 4(b)). As shown in Fig. 4(c), P_{G1} , P_{G2} , and P_{G3} gives three local peaks LP_1 , LP_2 and LP_3 .

Numerous researchers have studied the PSC effects on the characteristics of PV array through PV modeling [103–106]. For instance, in-depth examination of effects of PSC on PV was done in [109] while modeling, prediction, and experimental validations of power peaks of PV arrays under PSC has been accomplished in [107]. The effects of PSC on MPP were analyzed and it was indicated that the local MPPs may be categorized into high and low voltages MPPs based on the operating point of the PV system. Also, depending on the MPP voltage and current, it is quite possible to recognize the local and a global MPP at high voltages [108]. The influence of shadow on the performances of PV system for domestic water pumping system was done in North Algeria [109]. The analysis of partial shading problem in monolithically integrated thin-film PV modules demonstrated that the shape and size of the shadows also dictate their performance and reliability [110]. It was therefore noted that external bypass diodes could not protect the individual cells from shadow-induced reverse stress, but can only limit the string power output loss for larger shadows.

Regarding losses resulting from PSC, various works are

reported. A simple model for accurately computing the power losses resulting from a shaded PV system was proposed in [111]. Power losses resulting from diverse range of PV systems for various shading scenarios were calculated in comparison with those obtained with a detailed model based on solving the whole current–voltage curve. The results from the proposed model agreed with those from the detailed model. Authors in [112], introduced a generalized, quick and simple method for modeling and simulating the electrical behavior of PV installations under any shading situation which is mainly based on the Bishop modeling. So, the proposed method models PV-systems by discretizing currents and voltages in PV solar cell which are arranged in parallel and series associations (PV-cells, PV-groups, PV-modules, PV-strings and PV-array). The proposed method is used to provide a complete analysis of current, voltage and power in several PV systems under PSC. Power compensation system based on voltage are also used for PV system with PSC for complex unchanging insolation conditions [113]. The system results into better operation for non-shaded PV modules at normal MPP.

Proper configuration of PV array is also of utmost importance in handling PSC. Some methods to reconfigure the PV array under PSC have been proposed [114]. Optimal PV system reconfiguration reduces losses due to partial shading where a mathematical formulation in [115] suggests an equal or non-equal number of PV modules per row. Multi-input PV topologies for single and three phase stand-alone applications are also suggested to mitigate the effects of partial shading [116]. It is also noted by the researchers in [117] that the partial shading losses are less proportional to the shaded area but are determined by the array configuration, physical location of shaded modules in the array and shading pattern. Therefore they presented a technique for arrangement of the modules within the array in order to improve the PV output power. The outcome of the analysis indicated that positioning the modules according to “Su Do Ku” puzzle pattern results into enhanced performance for PSC.

Another problem that exists in partially shaded PV module is formation of hot spots [118]. Therefore, hot-spot suppression is a technique adopted to drive the PV to prevent the creation of hot spots without the need to use the bypass diodes. This method operates in connection with a model-based MPPT algorithm to find the best MPP while restricting the stress on shaded cells of the solar module.

5. MPPT for partial shading treatment

5.1. Artificial intelligent techniques for MPPT under PSC

It is well known that conventional MPPT techniques perform better with uniform irradiance [119]. However, with PSC, these MPPTs sometimes fail to track the MPP due to the presence of many local maxima that are formed on the PV characteristic curves. Therefore, AI methods have gained attention from the researchers to study the MPPT of PV systems under PSC because they are effective in this work. Several works have been done and are worth discussing in this section.

One of the intelligent MPPT methods for partially shaded PV system is the modified Fibonacci search (FS) method with FL. The MPPT using the actual FS fails to track the GMPP under PSC. The proposed approach enhances the technique with the use of wide search range and power ripple so that the GMPP is tracked for all conditions [120]. Adaptive fuzzy controllers for PV system under variable atmospheric and PSC were developed in conjunction with a modified IC MPPT algorithm [121].

A novel MPPT control strategy for PV modules using various partial shading and atmospheric was designed for constant solar

irradiation and PSC [122]. The aim was to attain proper tracking of MPP for PV system regardless of the variation of ambient temperature, characteristics of PV and solar irradiation.

An MPPT for PV system using Cuckoo search (CS) with partial shading capability was presented in [123]. In addition to reduced power loss of only 0.000008% in steady state due to MPP mismatch, CS is capable of tracking MPP within 100–250 ms under various types of environmental change.

The authors in [124] presented a technique achieved with an interleaved soft switched boost converter (ISSBC) connected to two PV panels which is applied even under PSC. The system was controlled by an adaptive NN-fuzzy inference system trained by data derived from a PSO unit. Simulation and experimental analysis of the model revealed better performance of the proposed algorithm when compared to other methods.

A modified FL controller for MPPT was proposed to improve the performance of the PV system during PSC [125]. As a replacement for P&O method to track MPP of the PV system, FL scans and keeps the maximum power during the perturbing and observing procedures and therefore offers accurate convergence to the global MPP under PSC.

Tabu search based MPPT method for PV systems under PSC was formulated with a combination of local search, diversification search and intensification search strategies to avoid the risk of trapping into the local MPP [126]. The development of the method, the authors argue that it was due to inability of the conventional MPPT techniques to discriminate between the local and global MPP.

The algorithm that acts by a heuristic search of array voltage was used to select the global MPP whereby the reference voltage of PV output is generated by heuristic search algorithm and used for perturbation [127]. After each perturbation, results are used for a succeeding search until a better convergence constraint is achieved. A modified version of heuristic search is a two-stage MPPT framework called estimation and revision (ER) introduced for PV under PSC. It combines the offline random search using metaheuristic algorithms with the conventional online MPPT method. Results suggested that the proposed ER-MPPT framework outperformed the conventional P&O in terms of efficiency and capability in tracking the global MPP [128].

Another MPPT method based on FL algorithm to realize simple control system for tracking the real MPP even under all changing environmental conditions was presented in [129]. The algorithm was proved to have better performances and very fast response.

Tagagi-Sugeno (TS) fuzzy based DC voltage control was also introduced to extract maximum power for the fluctuating weather and PSC. Under light load condition, unloaded operation of PV from its MPP is incorporated to sustain the real power balance of system [130].

5.2. Evolutionary programming techniques for MPPT under PSC

A deterministic PSO MPP tracker was applied for PV under PSC to improve tracking capability and eliminate the random number in the accelerations factor of the conventional PSO velocity equation [131]. The developed algorithm was evaluated by implementing it on a buck-boost converter while being compared to the conventional HC method. This method is proved with consistent solution at a small number of particles and only one parameter (the inertia weight) needs to be tuned. So, the method has a simple structure of MPPT in comparison to the conventional PSO.

A direct control based MPPT for PV system under PSCs are also being developed using particle swarm optimization algorithm [132]. The three particles (duty cycles) were initialized between these two limits, which are as follow:

$$d_{\min} = \frac{\sqrt{n_b R_{L \min}}}{\sqrt{R_{PV \max}} + \sqrt{n_b R_{L \min}}} \quad (2)$$

$$d_{\max} = \frac{\sqrt{n_b R_{L \max}}}{\sqrt{R_{PV \min}} + \sqrt{n_b R_{L \max}}} \quad (3)$$

Compared to the conventional direct duty cycle method, this method performs exceptionally well under all PSCs.

In [133], another attempt is carried out using a modified PSO (MPSO) to track the global peak under PSC. The proposed work is actually a modification of [132], where a middle particle between the two extremes duty cycles [Eqs. (2) and (3)] is proposed to

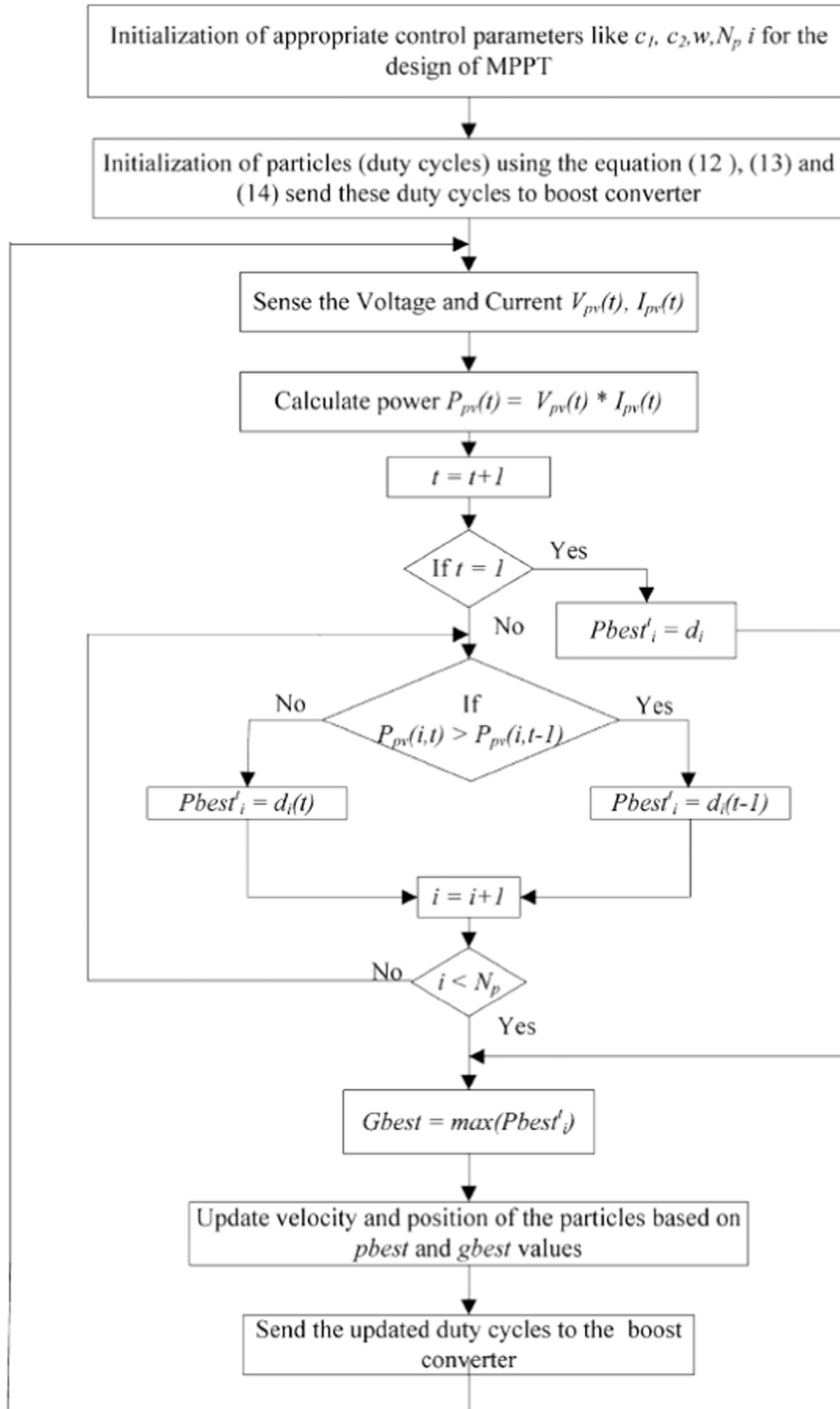

Fig. 5. Flowchart of the proposed MPSO method [133].

initiate the tracking optimization, which is given as:

$$d_{middle} = 1 - \frac{\sqrt{R_{in}}}{\sqrt{R_{out}}} \tag{4}$$

where, $R_{in}=(V_{mpp}/I_{mpp})$ is the internal resistance of a selected PV module and R_{out} is equivalent output load resistance. The modified version is well demonstrated thorough simulations and experiments. Their method was able to locate the global peak power under PSC, exhibiting faster dynamic response with slight steady state oscillations.

Fig. 5 depicts the flowchart of the proposed MPSO method.

A variant of PSO known as adaptive perceptive PSO was used for MPPT under PSC. This technique employed only one pair of sensors for controlling several PV arrays, resulting into higher accuracy of 97.7% which is more than the 96.41% obtained using normal PSO method [134]. Another low-cost GMPPT scheme for PV systems under PSC was also applied to improve the efficiency of power conversion in PV systems [135]. By using hybrid numerical searching process, the operating point approaches local MPPs (LMPPs) gradually and the GMPP is caught by comparing all the LMPPs.

In a separate work, Chao et al. [136] proposed an improved PSO algorithm to predict MPP of PV arrays with multi-peak P-V curves for shading and failure conditions. The proposed algorithm has better tracking speed, accuracy and response as compared to the conventional PSO algorithm. The proposed algorithm based MPPT control scheme is depicted in Fig. 6.

A modified differential evolution (MDE) algorithm was used for MPPT of PV system under partial shading condition in [102]. Unlike standard DE algorithm, this method has one tuning parameter, namely mutation factor, which is given as

$$V_{i,G} = X_{i,G} + \Phi \tag{5}$$

where, Φ is the duty cycle perturbation defined as

$$\Phi = F(X_{best,G} - X_{i,G}) \tag{6}$$

The proposed MDE algorithm outperforms the PSO as it always tracks the global peak. The MPPT control scheme utilized for the proposed method is shown in Fig. 7.

In [137], a novel MPPT based ant colony optimization for PV systems under PSC was presented. The feasibility of this technique was verified with the irradiance of various shading patterns through simulation. The analysis shows that the algorithm can track the GMPP efficiently and its robustness to various shading patterns was observed. A similar algorithm tracks the global power peak based on various critical observations from examination of PV characteristics. The tracking time of this approach is around one-tenth as compared to a conventional controller for PSC [138].

Authors in [139] proposed a novel artificial bee colony

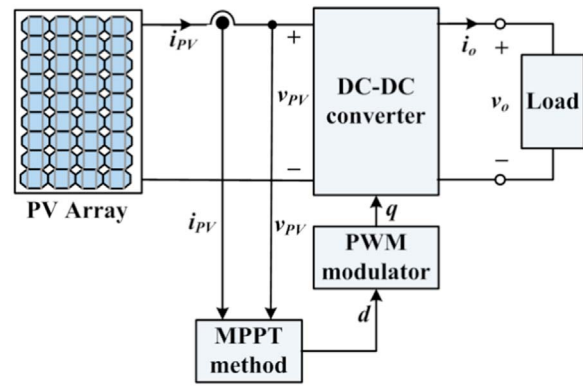

Fig. 7. MPPT control scheme with the proposed MDE algorithm [102].

algorithm for predicting the PV system MPP under PSC. The algorithm is developed to overcome the conventional methods drawback with simple and robust MPPT scheme. The artificial bees are divided into three classifications, i.e. employed, onlooker and scouts bees, as shown in Fig. 8. In the optimization process, the fitness of each duty cycle is given by:

$$P_i = \frac{P_{pv_i}}{\sum_{n=1}^{SN} P_{pv_i}} \tag{7}$$

5.3. Hybrid methods with conventional and artificial intelligence algorithms for MPPT of partially shaded PV systems

A simple and efficient hybrid MPPT technique for PV Systems under PSC was developed with a combination of P&O or IC and artificial neural network [140]. This approach was noted to be less costly with simple structure and fast response.

In a different work, a FL based P&O MPPT was studied using peak current control with variation of the reference current for better transient with improved steady-state performance [141]. The analysis showed an improved transient response of 15% and the power loss reduction in the steady state.

An ANN-polar coordinated fuzzy controller based MPPT control was applied for PV under PSC [142]. The FL with polar information controller utilizes the global MPP voltage as a reference voltage to produce the required control signal for the power converter and the MPPT is estimated through the ANN algorithm. Meanwhile, an ANN based modified IC algorithm for MPPT under PSC was simulated and implemented in hardware using FPGA [143].

A parallel tracking function was used to formulate an MPPT problem where the on-line hybrid FL-P&O MPPT algorithm is assisted to continuously search beyond the trapped MPP operating voltage point [144]. The operating voltage and current information

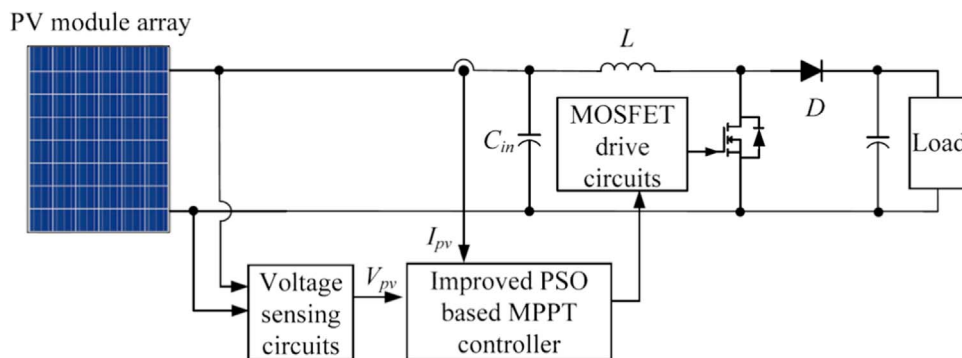

Fig. 6. MPPT control scheme with improved PSO algorithm [136].

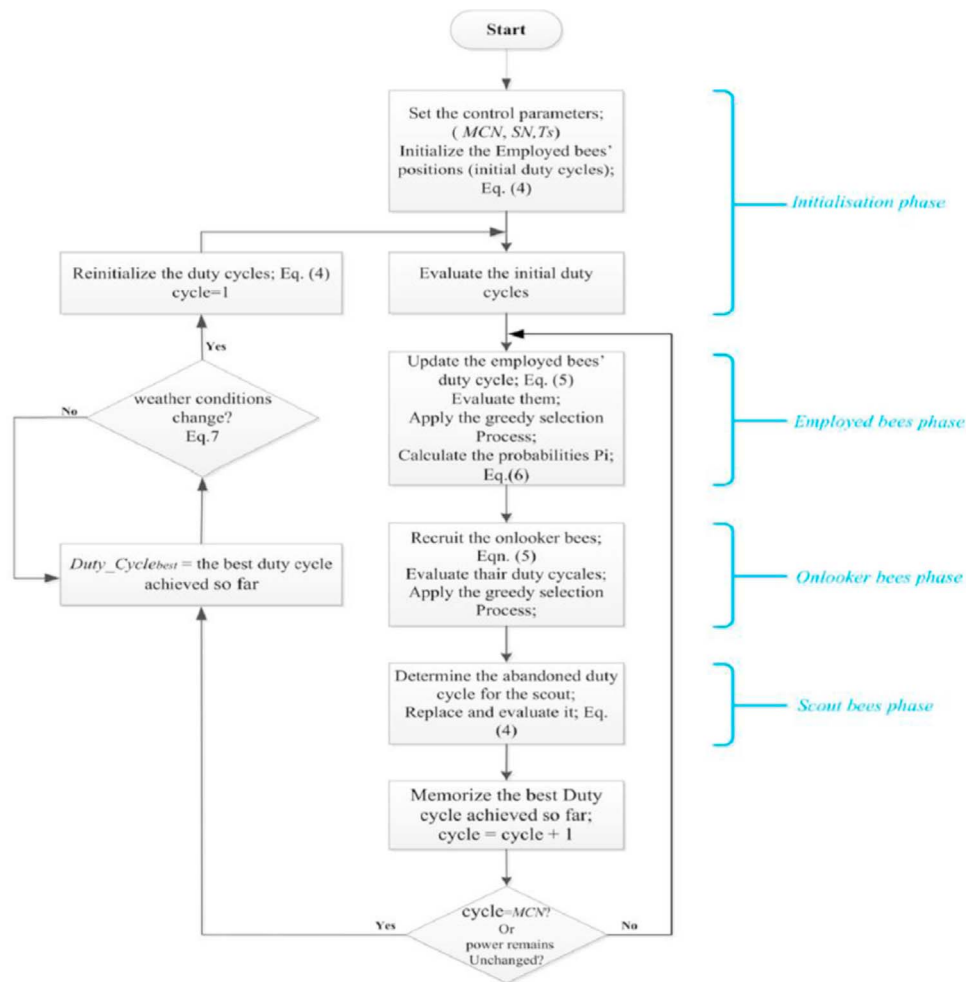

Fig. 8. The basic flowchart of artificial bee colony algorithm [139].

of the PV array are stored in the database while characteristics of the shaded array are estimated through simulation and the real MPP is identified through the tracking function. The analysis revealed that the improved FL-P&O MPPT method is able to track the real absolute MPP for PSC.

FL and P&O based MPPT for PV array under PSCs was implemented in MATLAB/Simulink [145]. FL is adopted into the conventional MPPT to enhance the overall PV system performance and for the optimization of the solar PV array under PSC. The method has improved performance because it can facilitate the PV array to reach the MPP faster and achieve a stable output power.

An MPPT algorithm based on a modified GA was also concentrated on tracking the GMPP in PV array with PSC [146]. A P&O algorithm was integrated into the GA function to create a single algorithm. The control part and the GMPPT algorithm were implemented on a digital signal processor and tested on an experimental small scale PV system. The algorithm does not need some sort of preset up configuration and can be directly applied to any type of PV characteristic with an unknown number of local MPPs.

The authors in [147] carried out the assessment of GA and conventional methods for MPPT of shaded solar PV generators. They concluded that IC and P&O algorithms fail to achieve MPP of the PV if the PV panel is under PSC. To solve this problem, GA algorithm was used and it successfully enabled the system to reach the global MPP.

A novel MPPT algorithm combining the improved P&O method and scanning technique to track the global power peak under PSC for BIPV was developed [37]. Alternatively, an MPPT Method for PV

Systems PSC was formulated where a global MPP searching technique is obtained by linking IC and scanning approach method which utilizes duty cycle sweep to track the global MPP when the PV array is under PSC [148].

A hybrid MPPT technique based on P&O and PSO indicated excellent performance [149]. P&O was employed to assign the nearest local maximum whereas the PSO technique was used to search for the GMPP.

MPPT of PV systems under PSCs through a colony of flashing fireflies was verified to have faster convergence, simple computational steps and low cost implementation on microcontroller [150]. The technique was studied for two dissimilar configurations of PV arrays under PSCs and the tracking performance compared with conventional P&O and PSO methods under identical conditions.

PV system MPPT control based on PSO-DE hybrid algorithm was tested under PSC. Compared with the PSO algorithm and DE algorithm, the hybrid tracking algorithm requires a much shorter time to reach the GMPP [151].

In another work [152], an ANN based hybrid MPPT algorithm was proposed. The basic idea of the proposed MPPT method is to use the ANN classifier to recognize the region of the global peak voltage from the irradiance values when irradiance sensors are available. Alternatively, the peak voltage is recognized from the measured current values on each stair of the I-V curve. The obtain information through ANN could be used to locally track the MPP using any conventional tracking algorithm. The effectiveness of the proposed MPPT is well proved using both simulations and an

experimental setup. The results shown to have more PV yield compared to other techniques and under various PSCs, their method can track the global MPP with fast tracking speed.

5.4. Other MPPT methods under PSC

Another MPPT technique based on bypass diode mechanism for PV arrays under PSC was presented in [153]. This technique was tested using the experimental data of 86.24 kW BIPV plant, consisting of partial shading patterns. The results indicated that because BD-MPPT was used, in most cases the efficiency of the BIPV plant reached at least 96.6%.

In contrast to the conventional MPPT algorithms which are effective for single peak PV characteristic under uniform solar irradiation, an adaptive MPPT method was modeled that has the capability to adjust tracking strategies to search for global peak area (GPA). Results established that the method is more effective for most types of shading conditions [154]. Another adaptive MPPT of PV system using short-current pulse to determine an optimum operating current for the MPP was found to offer an identification function by means of fast power versus current curve scanning that makes the short-current pulse based MPPT adaptive to disturbances such as partial shades covering the PV panels [155].

A cost effective single stage inverter with MPPT in combination with one-cycle control (OCC) ensures that the output current is proportional and in phase with the grid voltage [156]. Such operations are completed in one power stage with a simple control circuit and no detection and calculation of power are required. In a similar work, a dual-module-based MPPT control utilized the voltage and current information of each module which is shared and used for the detection of the MPP without measuring power [157]. On contrary, Kobayashi and Takano introduced a two stage MPPT control of a PV system for PSCs. It is a comparably simple control system that can track the real MPP for steady insolation as well as for rapidly changing insolation [158].

A complex algorithm to track the MPP in complex conditions was proposed and simulated in the PROTEUS simulation platform. It was verified to track the MPP faster and accurately [159]. Another technique for achieving maximum power from a mismatching and/or partially shaded PV modules is the use of module-integrated PV and converter units [160]. An MPPT method for mismatching compensation in PV Array under shaded conditions was analyzed according to the real MPP position and was proved with reduced circuit complexity [161].

A power electronics equalizer has also been applied to PV modules under PSC to eliminate the multiple MPP peaks that are common during this condition [162]. The elimination task was completed by equalizing the overall energy of the PV module through the use of only one inductive storage element. Additionally, control and circuit techniques are used to mitigate partial shading effects in PV arrays [163].

A new MPPT method for PV array system based on the scanning principle for the P-V curve under PSC was presented [164]. The current and voltage values of the capacitor connected the PV output are sensed within charging time.

MPPT algorithm based on I-V characteristic of PV array was introduced under uniform and non-uniform conditions. This is achieved by introducing an analytic condition to determine uniform or non-uniform atmospheric conditions as fast as possible [165]. Then, an operative and fast response technique is applied to find the MPP from the global peak and local peaks when the shading condition occurs, using analytic condition.

Monte Carlo algorithm with a probability statistics was also used as MPPT strategy for PV system under PSC to track the global power peak online [166]. With this method, it is possible to track MPP without having information on insolation and the

convergence speed is independent of multiple peaks of PV curve.

An exact MPPT of PV strings under PSC were developed based on current equalization concept (CEC) without making assumptions and to ensure each module is regulated at its exact MPP voltage [167]. Similarly, a comparison of model based MPPT and exact MPPT for CEC in PV strings revealed that the power output with exact MPPT method can be improved by approximately 10% as compared to model based method [168]. Alternatively, a voltage equalization distributed MPP extraction from a PV source shaded conditions equalizes the voltage across each module by operating each module close to their MPP [169].

An MPPT method based current-voltage characteristic of PV arrays was proposed in [170]. The study conducted under non-uniform and uniform insolation circumstances showed that the proposed algorithm is able to find a new MPP faster for a sudden change in the insolation level.

Another MPPT algorithm based on extremum seeking control (ESC) under uniform and non-uniform irradiances was introduced making use of series combination of a Low Pass Filter (LPF) and a High Pass Filter (HPF) [171]. Under PSC, the control method was found to be able to eliminate the interference of local MPP to make the PV array running at global MPP. Likewise, a sequential ESC-based global MPPT control was developed to deal with the multimodal-characteristics for PV array with variable shading [172]. Another adaptive ESC MPPT for PV guaranteed the convergence of the system to an adjustable neighborhood of the optimum by utilizing a Lyapunov adaptive control approach [173]. An improved ESC MPPT was tested to track the global power peak for grid-connected PV systems with PSC [174]. The method depends on the power gradient estimation and measurement to determine the segment of the P-V characteristics, in which the global peak lies, by means of iterations. Test results during PSC showed that the method can determine the global peak with higher tracking efficiency and a faster convergence rate than conventional approaches. On the other hand, gradient independent method called random search which is based on the use of random numbers to find the MPPT in partially shaded PV systems was presented [175]. The method was effective with varying shading patterns and tracking capability was compared with two-stage P&O and PSO based methods. In another study, [176] proposed a global perturbed-based ESC (GPESC) method to track the optimal peak of PV array under PSC. This scheme is shown to exhibit better performance than other global MPPT methods and it may revive the specialists' interest in applying this PESC scheme in PV applications and others multimodal problems from industry. Different PV and nonlinear multimodal patterns were used to validate the proposed GPESC.

MPPT algorithms are also developed for current balancing of partially shaded PV modules in order that the power output from PV can be increased. For example, the MPPT configuration in [177] produced more power when the solar radiation of the shading module was more than 20–30% of the other radiation of non-shading modules.

In [178], a current sweeping method to track the global peak under PSC is proposed. The initial control signal to track the optimal point is decided through current sweeping test and locating the correct maximum point could be further enhanced by a finer local search. Using a fast current control loop, the tracking speed can be easily improved. The flowchart of the proposed method is given in Fig. 9.

Fathabadi et al. proposed a Lambert W function-based discrete equations to obtain the MPP of PV arrays/panels [179]. The optimal PV power for various array topologies under any environmental conditions are determined by numerically solving these discrete equations. It is shown that the maximum PV power of an array strictly depends on the configuration of its PV modules. Their

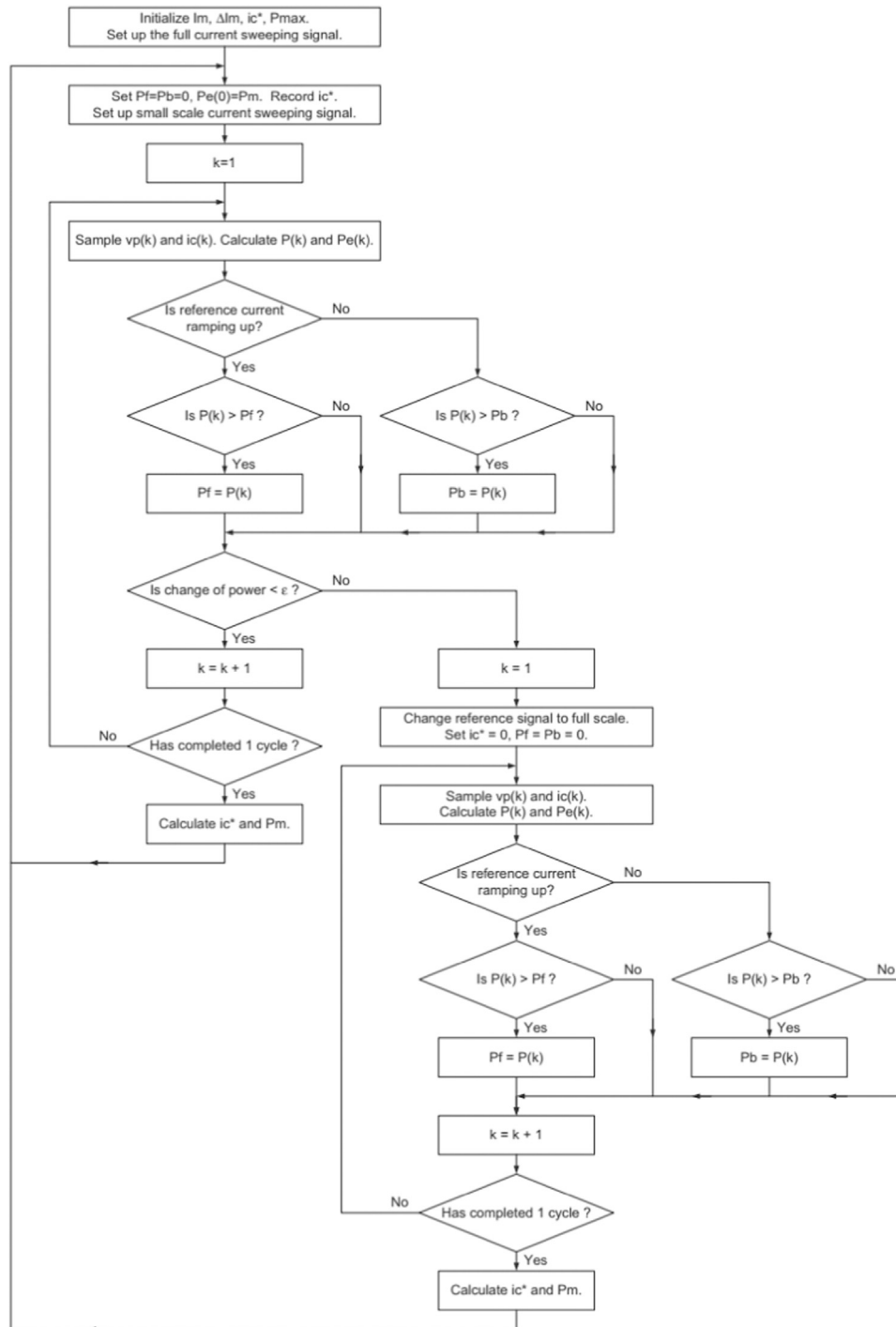

Fig. 9. The flowchart of the current sweeping method [178].

proposed technique shows a good agreement between the calculated parameters and the experimental data.

In [180], authors exploited the PV voltage and current deviations to find the MPP of a PV module/array/panel under any environmental condition. Under both uniform and shaded conditions, the proposed method was shown to have rapid convergence with more than 99.6% tracking efficiency, compared to other MPPT techniques. Fig. 10 shows the flowchart of the proposed method.

Considering the fact that multi-peak powers occur during PSC affects the tracking speed, Chen et al. [181] proposed the equal-power jumping MPPT method. It showed that the proposed method gives superior tracking speed compared to the full-range

searching method. Fig. 11 depicts the tracking root of the jumping method.

Authors in [182] proposed a golden-section using the interval shrinking technique to track the global MPP for PV systems under PSC. Initially, two control signals are selected to initiate the optimization process and boundaries of control signal keep on reducing to finally locate the optimal point. This makes the PV system converges rapidly to the MPP without voltage or power oscillations around the maximum power point thereby lower energy waste. Their method was validated using the recent published work and results were found to be satisfactory. The flowchart of the interval shrinking method is depicted in Fig. 12.

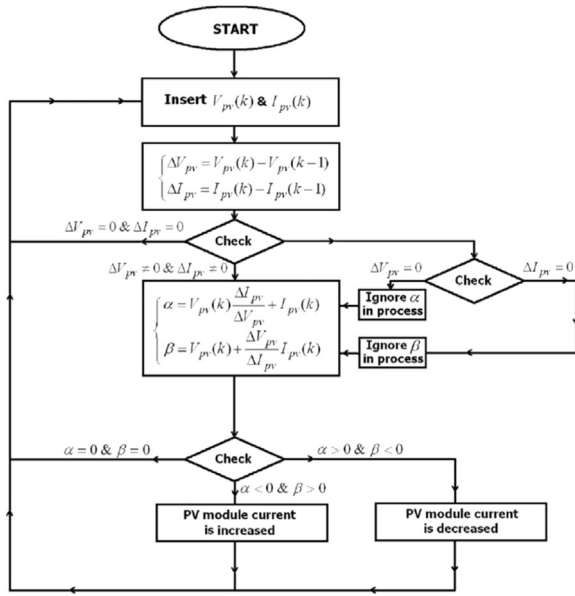

Fig. 10. Flowchart of the MPPT method based on the voltage and current deviations [180].

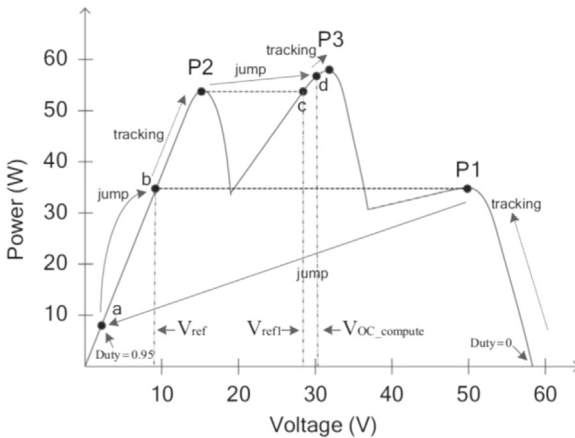

Fig. 11. The tracking root of the jumping method [181].

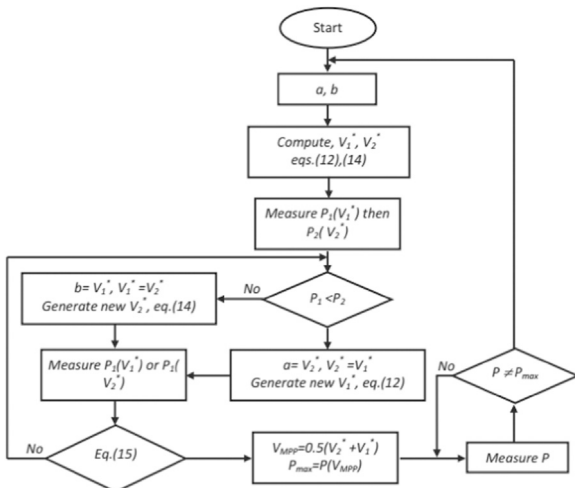

Fig. 12. The flowchart of the interval shrinking method [182].

6. Conclusion

It is well known that without proper tracking of the PV system

MPP, extraction of maximum power from PV system is not possible. Additionally, the PV system efficiency depends on how effectively the MPP is tracked more especially under PSC. In this work, a comprehensive review of MPPT methods for PV systems under normal condition and PSC has been presented. The MPPT methods have been categorized further as artificial intelligent, hybrid, and other MPPT methods. The comparison of researches on MPPT methods under normal condition and PSC reveals that researchers have concentrated more on PSC since the last few years. This was driven by the need to increase the power output and efficiency of PV systems. It is believed that the information contained in this paper will be of great use to the researchers in the field of PV system.

Acknowledgment

This project was funded by the Deanship of Scientific Research (DSR) at King Abdulaziz University, Jeddah, under grant no. (520/135/1434). The authors, therefore, acknowledge with thanks DSR for technical and financial supports.

References

- [1] Malla SG, Bhende CN. Enhanced operation of stand-alone photovoltaic-diesel generator-battery system. *Electr Power Syst Res* 2014;107:250–7.
- [2] Xiao W, Zeineldin HH, Zhang P, Member S. Statistic and parallel testing procedure for evaluating maximum power point tracking algorithms of photovoltaic power systems. *IEEE J Photovolt* 2013;3(3):1062–9.
- [3] Kong N, Ha DS. Low-power design of a self-powered piezoelectric energy harvesting system with maximum power. *IEEE Trans Power Electron* 2012;27(5):2298–308.
- [4] Fernando L, Villa L, Picault D, Raison B, Bacha S, Labonne A. Maximizing the power output of partially shaded photovoltaic plants through optimization of the interconnections among its modules. *IEEE J Photovolt* 2012;2(2):154–63.
- [5] Maurath D, Becker PF, Spreemann D, Manoli Y, Member S. Efficient energy harvesting with electromagnetic energy transducers using active low-voltage rectification and maximum power point tracking. *IEEE J Solid-State Circuits* 2012;47(6):1369–80.
- [6] Sahu HS. Power enhancement of partially shaded PV array by using a novel approach for shade dispersion. *Proc IEEE Innov Smart Grid Technol* 2014:498–503.
- [7] Ramli MZ, Salam Z. A simple energy recovery scheme to harvest the energy from shaded photovoltaic modules during partial shading. *IEEE Trans Power Electron* 2014;29(12):6458–71.
- [8] Barrade P, Delalay S, Member S, Rufer A. Direct connection of supercapacitors to photovoltaic panels with on-off maximum power point tracking. *IEEE Trans Sustain Energy* 2012;3(2):283–94.
- [9] Brecl K, Topic M. Self-shading losses of fixed free-standing PV arrays. *Renew Energy* 2011;36:3211–6.
- [10] Solórzano J, Egido MA. Automatic fault diagnosis in PV systems with distributed MPPT. *Energy Convers Manag* 2013;76:925–34.
- [11] Wu Y, Chen M, Huang S, Tsai M, Li C. Maximum power point tracking on stand-alone solar power system: three-point-weighting method incorporating mid-point tracking. *Int J Electr Power Energy Syst* 2013;52:14–24.
- [12] Itaka K. PCS with scanning-type mppt control for industrial grid-connected PV power generation system. In: *Proceedings International Power Electronics Conference*; 2014. p. 3244–3248.
- [13] Bouilouta A, Mellit A, Kalogirou SA. New MPPT method for stand-alone photovoltaic systems operating under partially shaded conditions. *Energy* 2013;55:1172–85.
- [14] Ponkarthik N, Murugavel KK. Performance enhancement of solar photovoltaic system using novel maximum power point tracking. *Int J Electr Power Energy Syst* 2014;60:1–5.
- [15] Balato M, Vitelli M. A new control strategy for the optimization of distributed MPPT in PV applications. *Int J Electr Power Energy Syst* 2014;62:763–73.
- [16] Mahammad AK, Saon S, Swee W. Development of optimum controller based on mppt for photovoltaic system during shading condition. *Procedia Eng* 2013;53:337–46.
- [17] JSCM Raj, Jeyakumar AE. A novel maximum power point tracking technique for photovoltaic module based on power plane analysis of I–V characteristics. *IEEE Trans Power Electron* 2014;61(9):4734–45.
- [18] Kadri R, Gaubert J, Champenois G. An Improved maximum power point tracking for photovoltaic grid-connected inverter based on voltage-oriented control. *IEEE Trans Ind Electron* 2011;58(1):66–75.

- [19] Sharma P, Agarwal V. Exact maximum power point tracking of grid-connected partially shaded pv source. *IEEE Trans Power Electron* 2014;29(9):4684–92.
- [20] Shah N. A novel algorithm for global peak power point tracking in partially shaded grid-connected PV system. In: *IEEE international conference on power and energy*; 2012. p. 2–5.
- [21] Ghoddami H, Yazdani A. A Single-stage three-phase photovoltaic system with enhanced maximum power point tracking capability and increased power rating. *IEEE Trans Power Deliv* 2011;26(2):1017–29.
- [22] Kuperman A, Averbukh M, Lineykin S. Maximum power point matching versus maximum power point tracking for solar generators. *Renew Sustain Energy Rev* 2013;19:11–7.
- [23] Konstantopoulos C, Koutroulis E. Global maximum power point tracking of flexible photovoltaic modules. *IEEE Trans Power Electron* 2014;29(6):2817–28.
- [24] Reza A, Hassan M, Jamasb S. Classification and comparison of maximum power point tracking techniques for photovoltaic system: a review. *Renew Sustain Energy Rev* 2013;19:433–43.
- [25] Ishaque K, Salam Z. A review of maximum power point tracking techniques of PV system for uniform insolation and partial shading condition. *Renew Sustain Energy Rev* 2013;19:475–88.
- [26] Bhatnagar P, Nema RK. Maximum power point tracking control techniques: state-of-the-art in photovoltaic applications. *Renew Sustain Energy Rev* 2013;23:224–41.
- [27] Eltawil MA, Zhao Z. MPPT techniques for photovoltaic applications. *Renew Sustain Energy Rev* 2013;25:793–813.
- [28] Subudhi B, Pradhan R. A comparative study on maximum power point tracking techniques for photovoltaic power systems. *IEEE Trans Sustain Energy* 2013;4(1):89–98.
- [29] Salam Z, Ahmed J, Merugu BS. The application of soft computing methods for MPPT of PV system: a technological and status review. *Appl Energy* 2013;107:135–48.
- [30] Karatepe E, Hiyama T. Performance enhancement of photovoltaic array through string and central based MPPT system under non-uniform irradiance conditions. *Energy Convers Manag* 2012;62:131–40.
- [31] Chin CS, Tan MK, Neelakantan P, Chua BL, Teo KTK. Optimization of partially shaded PV array using fuzzy MPPT. In: *IEEE Colloquium on Humanities, Science and Engineering Research*; 2011. p. 481–6.
- [32] Atharah N, Wei C. A comprehensive review of maximum power point tracking algorithms for photovoltaic systems. *Renew Sustain Energy Rev* 2014;37:585–98.
- [33] Carmela M, Piazza D, Vitale G. Photovoltaic field emulation including dynamic and partial shadow conditions. *Appl Energy* 2010;87(3):814–23.
- [34] Dolara A, Cristian G, Leva S, Manzolini G. Experimental investigation of partial shading scenarios on PV (photovoltaic) modules. *Energy* 2013;55:466–75.
- [35] Anani N, Shahid M, Al-kharji O, Ponciano J. Mediterranean green energy forum 2013 a cad package for modeling and simulation of PV arrays under partial shading conditions. *Energy Procedia* 2013;42:397–405.
- [36] Celik B, Karatepe E, Gokmen N, Silvestre S. A virtual reality study of surrounding obstacles on BIPV systems for estimation of long-term performance of partially shaded PV arrays. *Renew Energy* 2013;60:402–4.
- [37] Rong Y, Chen L. A new maximum power point tracking scheme for building integrated photovoltaic systems. In: *Proceedings of the International Conference on Instrumentation, Measurement, Computer, Communication and Control*; 2013. p. 622–627.
- [38] Attivissimo F, Adamo F, Carullo A, Maria A, Lanzolla L, Spertino F, Vallan A. On the performance of the double-diode model in estimating the maximum power point for different photovoltaic technologies. *Measurement* 2013;46(9):3549–59.
- [39] Carla M, Vincenzo D, Infield D. Detailed PV array model for non-uniform irradiance and its validation against experimental data. *Sol Energy* 2013;97:314–31.
- [40] Picault D, Raison B, Bacha S, De Casa J, Aguilera J. Forecasting photovoltaic array power production subject to mismatch losses. *Sol Energy* 2010;84(7):1301–9.
- [41] Martínez-Moreno F, Muñoz J, Lorenzo E. Experimental model to estimate shading losses on PV arrays. *Sol Energy Mater Sol Cells* 2010;94:2298–303.
- [42] Ishaque K, Salam Z, Taheri H. Modeling and simulation of photovoltaic (PV) system during partial shading based on a two-diode model. *Simul Model Pract Theory* 2011;19(7):1613–26.
- [43] Subiyanto S, Mohamed A, Hannan MA. Intelligent maximum power point tracking for PV system using Hopfield neural network optimized fuzzy logic controller. *Energy Build* 2012;51:29–38.
- [44] Rai AK, Kaushika ND, Singh B, Agarwal N. Simulation model of ANN based maximum power point tracking controller for solar PV system. *Sol Energy Mater Sol Cells* 2010;95:773–8.
- [45] Salah CB, Ouali M. Comparison of fuzzy logic and neural network in maximum power point tracker for PV systems. *Electr Power Syst Res* 2011;81(1):43–50.
- [46] Karatepe E, Hiyama T. Polar coordinated fuzzy controller based real-time maximum-power-point control of photovoltaic system. *Renew Energy* 2009;34(12):2597–606.
- [47] Kumar R, Shimi SL, Chatterji S, Ansari F. Modeling of solar PV module and maximum power point tracking using ANFIS. *Renew Sustain Energy Rev* 2014;33:602–12.
- [48] Nguyen TL, Low K. A global maximum power point tracking scheme employing direct search algorithm for photovoltaic systems. *IEEE Trans Ind Electron* 2010;57(10):3456–67.
- [49] Chen L, Tsai C, Lin Y, Lai Y. A biological swarm chasing algorithm for tracking the PV maximum power point. *IEEE Trans Energy Convers* 2010;25(2):484–93.
- [50] Mellit A, Kalogirou SA. MPPT-based artificial intelligence techniques for photovoltaic systems and its implementation into field programmable gate array chips: review of current status and future perspectives. *Energy* 2014;70:1–21.
- [51] Chekired F, Mellit A, Kalogirou SA, Larbes C. Intelligent maximum power point trackers for photovoltaic applications using FPGA chip: a comparative study. *Sol Energy* 2014;101:83–99.
- [52] Mellit A, Rezzouk H, Messai A, Medjahed B. FPGA-based real time implementation of MPPT-controller for photovoltaic systems. *Renew Energy* 2011;36(5):1652–61.
- [53] Parlak KS. FPGA based new MPPT (maximum power point tracking) method for PV (photovoltaic) array system operating partially shaded conditions. *Energy* 2014;68:399–410.
- [54] Al-mohaya MAM, Mahamad AK, Saon S. Implementation of field programmable gate array based maximum power point tracking controller of photovoltaic system. In: *IEEE 7th International Power Engineering and Optimization Techniques*; 2013. p. 718–721.
- [55] Dounis AI, Kofinas P, Papadakis G, Alafodimos C. A direct adaptive neural control for maximum power point tracking of photovoltaic system. *Sol Energy* 2015;115:145–65.
- [56] Ghassami AA, Sadeghzadeh SM, Soleimani A. A high performance maximum power point tracker for PV systems. *Int J Electr Power Energy Syst* 2013;53:237–43.
- [57] Souza NSD, Lopes LAC, Liu X. Comparative study of variable size perturbation and observation maximum power point trackers for PV systems. *Electr Power Syst Res* 2010;80:296–305.
- [58] Ishaque K, Salam Z, Lauss G. The performance of perturb and observe and incremental conductance maximum power point tracking method under dynamic weather conditions. *Appl Energy* 2014;119:228–36.
- [59] Houssamo I, Locment F, Sechilariu M. Experimental analysis of impact of MPPT methods on energy efficiency for photovoltaic power systems. *Int J Electr Power Energy Syst* 2013;46:98–107.
- [60] Veerachary M, Senjyu T, Uezato K. Neural-network-based maximum-power-point tracking of coupled-inductor interleaved-boost-converter-supplied PV system using fuzzy controller. *IEEE Trans Ind Electron* 2003;50(4):749–58.
- [61] Moradi MH, Tousi SMR, Nemati M, Basir NS, Shalavi N. A robust hybrid method for maximum power point tracking in photovoltaic systems. *Sol Energy* 2013;94:266–76.
- [62] Zhang F, Thanapalan K, Procter A, Carr S, Maddy J. Adaptive hybrid maximum power point tracking method for a photovoltaic system. *IEEE Trans Energy Convers* 2013;28(2):353–60.
- [63] Bennett T, Zilouchian A, Messenger R. A proposed maximum power point tracking algorithm based on a new testing standard. *Sol Energy* 2013;89:23–41.
- [64] Huang B, Ton W, Wu C, Ko H, Chang H, Yen R, Wang J. Maximum-power-point tracking control of solar heating system. *Sol Energy* 2012;86(11):3278–87.
- [65] Kim H, Member S, Kim S, Kwon C, Min Y, Kim C, Kim S. An energy-efficient fast maximum power point tracking circuit in an 800- μ W photovoltaic energy harvester. *IEEE Trans Power Electron* 2013;28(6):2927–35.
- [66] Levron Y, Shmilovitz D. Maximum power point tracking employing sliding mode control. *IEEE Trans Circuits Syst* 2013;60(3):724–32.
- [67] Khanna R, Zhang Q, Stanchina WE, Reed GF. Maximum power point tracking using model reference adaptive control. *IEEE Trans Power Electron* 2014;29(3):1490–9.
- [68] Lee K, Kim R. An adaptive maximum power point tracking scheme based on a variable scaling factor for photovoltaic systems. *IEEE Trans Energy Convers* 2012;27(4):1002–8.
- [69] Jain S, Agarwal V. A new algorithm for rapid tracking of approximate maximum power point in photovoltaic systems. *IEEE Power Electron Lett* 2004;2(1):16–9.
- [70] Esham T, Member S, Kimball JW, Member S, Krein PT, Chapman PL, Midya P. Dynamic maximum power point tracking of photovoltaic arrays using ripple correlation control. *IEEE Trans Power Electron* 2006;21(5):1282–91.
- [71] Kimball JW, Krein PT. Discrete-time ripple correlation control for maximum power point tracking. *IEEE Trans Power Electron* 2008;23(5):2353–62.
- [72] Kumar G, Panchal AK. Geometrical prediction of maximum power point for photovoltaics. *Appl Energy* 2014;119:237–45.
- [73] Vaidya V, Wilson D. Maximum power tracking in solar cell arrays using time-based reconfiguration. *Renew Energy* 2013;50:74–81.
- [74] Xiao W, Dunford WG, Palmer PR, Capel A. Application of centered differentiation and steepest descent to maximum power point tracking. *IEEE Trans Ind Electron* 2007;54(5):2539–49.
- [75] Chun S, Kwasinski A. Analysis of classical root-finding methods applied to digital maximum power point tracking for sustainable photovoltaic energy generation. *IEEE Trans Power Electron* 2011;26(12):3730–43.
- [76] Pai F, Chao R, Ko SH, Lee T. Performance evaluation of parabolic prediction to maximum power point tracking for pv array. *IEEE Trans Sustain Energy* 2011;2(1):60–8.
- [77] Yang C, Hsieh C, Feng F, Chen K. Highly efficient analog maximum power

- point tracking (amppt) in a photovoltaic system. *IEEE Trans Circuits Syst* 2012;59(7):1546–56.
- [78] Faridun M, Tajuddin N, Ayob S. Evolutionary based maximum power point tracking technique using differential evolution algorithm. *Energy Build* 2013;67:245–52.
- [79] Zhao J, Zhou X, Mab Y, Liu W. A novel maximum power point tracking strategy based on optimal voltage control for photovoltaic systems under variable environmental conditions. *Sol Energy* 2015;122:640–9.
- [80] Zhang F, Maddy J, Premier G, Guwy A. Novel current sensing photovoltaic maximum power point tracking based on sliding mode control strategy. *Sol Energy* 2015;118:80–6.
- [81] Montoya DG, Paja CAR, Giral R. Maximum power point tracking of photovoltaic systems based on the sliding mode control of the module admittance. *Electr Power Syst Res* 2016;136:125–34.
- [82] Du Y, Lu DD. Battery-integrated boost converter utilizing distributed MPPT configuration for photovoltaic systems. *Sol Energy* 2011;85(9):1992–2002.
- [83] Mirbagheri SZ, Mekhilef S, Mirhassani SM. MPPT with IncCond method using conventional interleaved boost converter. *Energy Procedia* 2013;42:24–32.
- [84] Petreus D. Low cost single stage micro-inverter with MPPT for grid connected applications. *Sol Energy* 2013;92:241–55.
- [85] Matsui M, Sai T, Kitamura A, Sunt X, Yu B. A novel current link distributed MPPT PV system - Overall system prototyping and evaluation. In: Proceedings of the International power electronics conference; 2014. p. 3784–3788.
- [86] Li S. A MPPT control strategy with variable weather parameter and no DC/DC converter for photovoltaic systems. *Sol Energy* 2014;108:117–25.
- [87] Bifaretti S, Iacovone V, Cinà L, Buffone E. Global MPPT method for partially shaded photovoltaic modules. In: Proceedings IEEE energy conversion congress and exposition; 2012. p. 4768–75.
- [88] Moon S, Kim S, Seo J, Park J, Park C, Chung C. Maximum power point tracking without current sensor for photovoltaic module integrated converter using Zigbee wireless network. *Int J Electr Power Energy Syst* 2014;56:286–97.
- [89] Sánchez CR, Milone DH, Buitrago RH. Simulation of photovoltaic centrals with dynamic shading. *Appl Energy* 2013;103:278–89.
- [90] Zheng H, Li S, Challoor R, Proano J. Shading and bypass diode impacts to energy extraction of PV arrays under different converter configurations. *Renew Energy* 2014;68:58–66.
- [91] Veerachary M, Senjyu T, Uezato K. Maximum power point tracking control of IDB converter supplied PV system. *IEE Proceedings Electric Power Applications*; 2001, 148, 6, p. 494–502.
- [92] Veerachary M, Senjyu T, Uezato K. Voltage-based maximum power point tracking control of PV system. *IEEE Trans Aerosp Elect Syst* 2002;38(1):262–70.
- [93] Veerachary M, Senjyu T, Uezato K. Maximum power point tracking of coupled inductor interleaved boost converter supplied PV system. *IEEE Proc. Electric Power Appl* 2003;150, 1, p. 71–80.
- [94] Uno M, Kukita A. Single-switch voltage equalizer using multi-stacked buck-boost converters for partially-shaded photovoltaic modules. *IEEE Trans Power Electron* 2014 PP(99):1.
- [95] Veerachary M. Fourth-order buck converter for maximum power point tracking applications. *IEEE Trans Aerosp Elect Syst* 2011;47(2):896–901.
- [96] Pragallapati N, Agarwal V. Flyback configuration based micro-inverter with distributed mppt of partially shaded PV module and energy recovery scheme. In: Proceedings of the IEEE 39th Photovoltaic Specialists Conference; 2013. p. 2927–2931.
- [97] Peter PK, Sharma P, Agarwal V. Switched capacitor dc-dc converter based current equalization scheme for maximum power extraction from partially shaded PV modules without bypass diodes. In: Proceedings of the IEEE Photovoltaic Specialists Conference; 2012. p. 1422–1427.
- [98] Sharma P, Agarwal V, Member S. Maximum power extraction from a partially shaded pv array using shunt-series compensation. *IEEE J Photovolt* 2014;4(4):1128–37.
- [99] Fortunato M, Giustiniani A, Petrone G, Spagnuolo G, Vitelli M. Maximum power point tracking in a one-cycle-controlled single-stage photovoltaic inverter. *IEEE Trans Ind Electron* 2008;55(7):2684–93.
- [100] Jiang S, Member S, Cao D, Li Y. Grid-connected boost-half-bridge photovoltaic microinverter system using repetitive current control and maximum power point tracking. *IEEE Trans Power Electron* 2012;27(11):4711–22.
- [101] Meller Y, Kribus A. Kaleidoscope homogenizers sensitivity to shading. *Sol Energy* 2013;88:204–14.
- [102] Ramli MAM, Ishaque K, Jawaid F, Al-Turki YA, Salam ZA. Modified differential evolution based maximum power point tracker for photovoltaic system under partial shading condition. *Energy Build* 2015;103:175–84.
- [103] Patel H, Agarwal V. MATLAB-based modeling to study the effects of partial shading on pv array characteristics. *IEEE Trans Energy Convers* 2008;23(1):302–10.
- [104] Moballeggh S, Jiang J. Modeling, prediction, and experimental validations of power peaks of PV arrays under partial shading conditions. *IEEE Trans Sustain Energy* 2014;5(1):293–3004.
- [105] S. Moballeggh, Jiang J. Partial shading modeling of photovoltaic system with experimental validations. In: Proc. IEEE power and energy social general meeting; 2011. p. 1–9.
- [106] Gao L, Dougal RA, Liu S, Iotova AP. Parallel-connected solar PV system to address partial and rapidly fluctuating shadow conditions. *IEEE Trans Ind Electron* 2009;56(5):1548–56.
- [107] Zang F, Li J, Feng C, Wu Y. In-depth investigation of effects of partial shading on PV array characteristics. In: Proceedings of the IEEE Power Engineering and Automation Conference (PEAM);2012. p.1–4.
- [108] Valkealahti S. Differentiation of multiple maximum power points of partially shaded photovoltaic power generators. *Renew Energy* 2014;71:89–99.
- [109] Mohammadi A, Mezzai N, Rekioua D, Rekioua T. Impact of shadow on the performances of a domestic photovoltaic pumping system incorporating an MPPT control: a case study in Bejaia, North Algeria. *Energy Convers Manag* 2014;84:20–9.
- [110] Dongaonkar S, Member S, Deline C, Alam MA. Performance and reliability implications of two-dimensional shading in monolithic thin-film photovoltaic modules. *IEEE J Photovolt* 2013;3(4):1367–75.
- [111] Rodrigo P, Fernandez EF, Almonacid F, Perez-Higueras PJ. A simple accurate model for the calculation of shading power losses in photovoltaic generators. *Sol Energy* 2013;93:322–33.
- [112] Carrillo C. Discrete I–V model for partially shaded PV-arrays. *Sol Energy* 2014;103:96–107.
- [113] Karatepe E, Hiyama T, Boztepe M, Metin C. Voltage based power compensation system for photovoltaic generation system under partially shaded insolation conditions. *Energy Convers Manag* 2008;49:2307–16.
- [114] Koray S. PV array reconfiguration method under partial shading conditions. *Int J Electr Power Energy Syst* 2014;63:713–21.
- [115] Salama MMA. Optimal photovoltaic array reconfiguration to reduce partial shading losses. *IEEE Trans Sustain Energy* 2013;4(1):145–53.
- [116] Wandhare RG, Agarwal V, Jain S. Novel multi-input solar PV topologies for 1-phase and 3-phase stand alone applications to mitigate the effects of partial shading. In: Proceedings of the Applied power electronics conference and exposition; 2013. p. 76–83.
- [117] Rani BI, Ilango GS, Nagamani C. Enhanced power generation from PV array under partial shading conditions by shade dispersion using Su Do Ku configuration. *IEEE Trans Sustain Energy* 2013;4(3):594–601.
- [118] Spanoche SA, Stewart JD, Hawley SL, Opris IE. Model-based method for partially shaded pv module hot-spot suppression. *IEEE J Photovolt* 2013;3(2):785–90.
- [119] Ji Y, Jung D, Won C, Lee B, Kim J. Maximum power point tracking method for PV array under partially shaded condition. In: Proceedings of the IEEE Energy conversion congress and exposition; 2009. p. 307–12.
- [120] Ramaprabha R, Balaji M, Mathur BL. Maximum power point tracking of partially shaded solar PV system using modified Fibonacci search method with fuzzy controller. *Int J Electr Power Energy Syst* 2012;43(1):754–65.
- [121] Punitha K, Devaraj D, Sakthivel S. Development and analysis of adaptive fuzzy controllers for photovoltaic system under varying atmospheric and partial shading condition. *Appl Soft Comput J* 2013;13(11):4320–32.
- [122] Tsai M, Tseng C, Hong G, Lin S. A novel mppt control design for PV modules using neural network compensator. In: Proceedings of the IEEE International Symposium on Industrial Electronics; 2012. p. 1742–47.
- [123] Ahmed J, Salam Z. A Maximum power point tracking (MPPT) for PV system using Cuckoo Search with partial shading capability. *Appl Energy* 2014;119:118–30.
- [124] Muthuramalingam M, Manoharan PS. Comparative analysis of distributed MPPT controllers for partially shaded stand alone photovoltaic systems. *Energy Convers Manag* 2014;86:286–99.
- [125] Alajimi BN, Ahmed KH, Finney SJ, Williams BW. A maximum power point tracking technique for partially shaded photovoltaic systems in microgrids. *IEEE Trans Ind Electron* 2013;60(4):1596–606.
- [126] Zheng Y, Wei C, Lin S. A maximum power point tracking method based on tabu search for PV systems under partially shaded conditions. In: Proceedings of the IET conference on renewable power generation; 2011. p. 6–9.
- [127] Mohajeri HR, Moghaddam MP, Shahparasti M, Mohamadian M. Development a new algorithm for maximum power point tracking of partially shaded photovoltaic arrays. In: Proceedings of the Iranian Conference on Electrical Engineering; 2012. p. 489–494.
- [128] Ma J, Man KL, Ting TO, Zhang N, Guan S, Wong PWH. Estimation and revision: A framework for maximum power point tracking on partially shaded photovoltaic arrays. In: Proceedings of the International symposium on computer, (consumer and control); 2014. 162–165.
- [129] Ahmed NA, Miyatake M. A novel maximum power point tracking for photovoltaic applications under partially shaded insolation conditions. *Electr Power Syst Res* 2008;78:777–84.
- [130] Chiu C. T-S fuzzy maximum power point tracking control of solar power generation systems. *IEEE Trans Energy Convers* 2010;25(4):1123–32.
- [131] Ishaque K, Salam Z. A deterministic particle swarm optimization maximum power point tracker for photovoltaic system under partial shading condition. *IEEE Trans Ind Electron* 2013;60(8):3195–206.
- [132] Ishaque K, Salam Z, Shamsudin A, Amjad M. A direct control based maximum power point tracking method for photovoltaic system under partial shading conditions using particle swarm optimization algorithm. *Appl Energy* 2012;99:414–22.
- [133] Babu TS, Rajasekar N, Sangeetha K. Modified particle swarm optimization technique based maximum power point tracking for uniform and under partial shading condition. *Appl Soft Comput* 2015;34:613–24.
- [134] Chowdhury SR, Saha H. Maximum power point tracking of partially shaded solar photovoltaic arrays. *Sol Energy Mater Sol Cells* 2010;94(9):1441–7.
- [135] Ma J, Man KL, Ting TO, Zhang N, Lei C, Wong N. Low-cost global MPPT scheme for photovoltaic systems under partially shaded conditions. In: Proceedings of the IEEE International Symposium on Circuits and Systems, 2013. p. 245–248.

- [136] Chao K, Lin Y, Lai U. Improved particle swarm optimization for maximum power point tracking in photovoltaic module arrays. *Appl Energy* 2015;158:609–18.
- [137] Lian L, Maskell DL, Patra JC. A novel ant colony optimization-based maximum power point tracking for photovoltaic systems under partially shaded conditions. *Energy Build* 2013;58:227–36.
- [138] Patel H, Agarwal V. Maximum power point tracking scheme for PV systems operating under partially shaded conditions. *IEEE Trans Ind Electron* 2008;55(4):1689–98.
- [139] Benyoucef AS, Chouder A, Kara K, Silvestre A, Sahed OA. Artificial bee colony based algorithm for maximum power point tracking (MPPT) for PV systems operating under partial shaded conditions. *Appl Soft Comput* 2015;32:38–48.
- [140] Lian L, Nayanisiri DR, Maskell DL, Vilathgamuwa DM. A simple and efficient hybrid maximum power point tracking method for pv systems under partially shaded condition. In: *Proceedings of the Annual Conference on IEEE Industrial Electronics Society*; 2013. p. 14–19.
- [141] Souza NSD, Lopes LAC, Liu X. An intelligent maximum power point tracker using peak current control. In: *Proceedings of the IEEE Power Electronics Specialists Conference*; 2005. p. 172–177.
- [142] Syafaruddin, Karatepe E, Hiyama T. Artificial neural network-polar coordinated fuzzy controller based maximum power point tracking control under partially shaded conditions. *IET Renew Power Gener* 2009;3(2):239–53.
- [143] Punitha K, Devaraj D, Sakthivel S. Artificial neural network based modified incremental conductance algorithm for maximum power point tracking in photovoltaic system under partial shading conditions. *Energy* 2013;62:330–40.
- [144] Chin CS, Neelakantan P, Yong HP, Yang SS, Teo KTK. Maximum power point tracking for PV array under partially shaded conditions. In: *Proceedings of the International conference on computational intelligence, (communication systems and networks)*; 2011. p. 72–77.
- [145] Chin CS, Chin YK, Chua BL, Kiring A, Teo KTK. Fuzzy logic based mppt for PV array under partially shaded conditions. In: *Proceedings of the International conference on advanced computer science applications and technologies*; 2012. p. 133–138.
- [146] Daraban S, Petreus D, Morel C. A novel MPPT (maximum power point tracking) algorithm based on a modified genetic algorithm specialized on tracking the global maximum power point in photovoltaic systems affected by partial shading. *Energy* 2014;74:374–88.
- [147] Shaiek Y, Ben Smida M, Sakly A, Mimouni MF. Comparison between conventional methods and GA approach for maximum power point tracking of shaded solar PV generators. *Sol Energy* 2013;90:107–22.
- [148] Ünlü M, Çamur S, Arifoglu B. A new maximum power point tracking method for PV systems under partially shaded conditions. In: *Proceedings of the International conference on power engineering, energy and electrical drives*; 2013. p. 13–17.
- [149] Lian KL, Jhang JH, Tian IS. A maximum power point tracking method based on perturb-and-observe combined with particle swarm optimization. *IEEE J Photovolt* 2014;4(2):626–33.
- [150] Sundareswaran K, Peddapati S, Palani S. MPPT of PV systems under partial shaded conditions through a colony of flashing fireflies. *IEEE Trans Energy Convers* 2014;29(2):463–72.
- [151] Li F, Deng F, Guo S, Fan X. MPPT control of PV system under partially shaded conditions based on PSO-DE hybrid algorithm. In: *Proceedings of the Chinese control conference*; 2013. p. 7553–7557.
- [152] Jiang LL, Nayanisiri DR, Maskell DL, Vilathgamuwa DM. A hybrid maximum power point tracking for partially shaded photovoltaic systems in the tropics. *Renew Energy* 2015;76:53–65.
- [153] Murtaza A, Chiaberge M, Spertino F, Boero D, De Giuseppe M. A maximum power point tracking technique based on bypass diode mechanism for PV arrays under partial shading. *Energy Build* 2013;73:13–25.
- [154] Qj J, Zhang Y, Chen Y. Modeling and maximum power point tracking (MPPT) method for PV array under partial shade conditions. *Renew Energy* 2014;66:337–45.
- [155] Toshihiko N, Shigenori T, Ryo N. Short-current pulse based adaptive maximum-power-point tracking for photovoltaic power generation system. In: *Proceedings of the IEEE International symposium on industrial electronics*; 2000. p. 157–162.
- [156] Chen Y, Smedley KM. A cost-effective single-stage inverter with maximum power point tracking. *IEEE Trans Power Electron* 2004;19(5):1289–94.
- [157] Park J, Ahn J, Cho B, Yu G. Dual-module-based maximum power point tracking control of photovoltaic systems. *IEEE Trans Ind Electron* 2006;53(4):1036–47.
- [158] Kobayashi K, Takano I. A study on a two stage maximum power point tracking control of a photovoltaic system under partially shaded insolation conditions. In: *Proceedings of the IEEE power engineering society general meeting*; 2003. p. 2612–2617.
- [159] Cuia Y, Yao W, Luo J. Research and improvement on a maximum power point tracking method for PV system under partially shaded conditions. *Procedia Eng* 2012;29:2583–9.
- [160] Chong BVP, Zhang L. Controller design for integrated PV-converter modules under partial shading conditions. *Sol Energy* 2013;92:123–38.
- [161] Ji Y, Jung D, Kim J, Kim J, Lee T. A real maximum power point tracking method for mismatching compensation in PV array under partially shaded conditions. *IEEE Trans Power Electron* 2011;26(4):1001–9.
- [162] Fernando L, Villa L, Ho T, Crebier J, Raison B. A power electronics equalizer application for partially shaded photovoltaic modules. *IEEE Trans Ind Electron* 2013;60(3):1179–90.
- [163] Bidram A, Davoudi A, Balog RS. Control and circuit techniques to mitigate partial shading effects in photovoltaic arrays. *IEEE J Photovolt* 2012;2(4):532–46.
- [164] Koray HC, Parlak S. A new MPPT method for PV array system under partially shaded conditions. In: *Proceedings of the International Symposium Power Electronic for Distributed Generation System*; 2012. p. 437–441.
- [165] Kouchaki A, Asaei B. Maximum power point tracking algorithm based on I-V characteristic of PV array under uniform and non-uniform conditions. In: *Proceedings IEEE international conference on power and energy*; 2012. p. 2–5.
- [166] Tang L, Xu W, Jin JX. Novel maximum power point tracking strategy for photovoltaics system under partially shaded condition based Monte Carlo algorithm. In: *Proceedings of the IEEE international conference on applied superconductivity and electromagnetic devices*; 2013. p. 285–286.
- [167] Sharma P, Peter PK, Agarwal V. Exact maximum power point tracking of partially shaded PV strings based on current equalization concept. In: *Proceedings IEEE Photovoltaic Specialists Conference*; 2012. p. 1411–1416.
- [168] Sharma P, Agarwal V. Comparison of model based MPPT and exact MPPT for current equalization in partially shaded PV strings. In: *Proceedings of the IEEE photovoltaic specialists conference*; 2013. p. 2948–2952.
- [169] Pragallapati N, Sharma P, Agarwal V. A new voltage equalization based distributed maximum power point extraction from a PV source operating under partially shaded conditions. In: *Proceedings of the 39th IEEE photovoltaic specialists conference*; 2013. p. 2921–2926.
- [170] Kouchaki A, Iman-eini H, Asaei B. A new maximum power point tracking strategy for PV arrays under uniform and non-uniform insolation conditions. *Sol Energy* 2013;91:221–32.
- [171] Heydari-dooostabad H, Keypour R, Reza M. A new approach in MPPT for photovoltaic array based on extremum seeking control under uniform and non-uniform irradiances. *Sol Energy* 2013;94:28–36.
- [172] Lei P, Li Y, Seem JE. Sequential ESC-based global MPPT control for photovoltaic array with variable shading. *IEEE Trans Sustain Energy* 2011;2(3):348–58.
- [173] Li X, Li Y, Seem JE. Maximum power point tracking for photovoltaic system using adaptive extremum seeking control. *IEEE Trans Control Syst Technol* 2013;21:2315–22.
- [174] Elnosh A, Khadkikar V, Xiao W, James L. An improved extremum - seeking based MPPT for grid - connected PV systems with partial shading. In: *Proceedings of the IEEE 23rd International Symposium on Industrial Electronics*; 2014. p. 2548–2553.
- [175] Sundareswaran K, Peddapati S, Palani S. Application of random search method for maximum power point tracking in partially shaded photovoltaic systems. *IET Renew Power Gener* 2013;8:670–78.
- [176] Bizon N. Global Maximum Power Point Tracking (GMPPT) of photovoltaic array using the Extremum Seeking Control (ESC): a review and a new GMPPT ESC scheme. *Renew Sustain Energy Rev* 2016;57:524–39.
- [177] Bellini A, Bifaretti S, Iacovone V. MPPT algorithm for current balancing of partially shaded photovoltaic modules. In: *Proceedings of the IEEE international symposium on industrial electronics*; 2010. p. 933–938.
- [178] Tsang KM, Chan WL. Maximum power point tracking for PV systems under partial shading conditions using current sweeping. *Energy Convers Manag* 2015;93:249–2.
- [179] Fathabadi H. Lambert W function-based technique for tracking the maximum power point of PV modules connected in various configurations. *Renew Energy* 2015;74:214–26.
- [180] Fathabadi H. Novel fast dynamic MPPT (maximum power point tracking) technique with the capability of very high accurate power tracking. *Energy* 2016;94:466–75.
- [181] Chen Y, Jhang Y, Kuo T, Liang R, Hung C. Jumping maximum power point tracking method for PV array under partially shaded conditions. *Sol Energy* 2016;132:617–27.
- [182] Kheldoun A, Bradai R, Boukenoui R, Mellit A. A new Golden Section method-based maximum power point tracking algorithm for photovoltaic systems. *Energy Convers Manag* 2016;111:125–36.