

Rising above vulnerability: resilience and sustainable livelihood outcomes of national park-adjacent communities in an African biodiversity hotspot

Journal of
Humanities and
Applied Social
Sciences

Michelle Kiconco

*Department of Leisure and Hospitality Management,
Makerere University Business School, Kampala, Uganda*

Kassim Alinda

*Department of Accounting, Makerere University Business School,
Kampala, Uganda*

Immaculate Mary Mbabazi and James Mutabazi

*Department of Tourism, Makerere University Business School,
Kampala, Uganda, and*

Cynthia Kauami Ngunoue

Namibia University of Science and Technology, Windhoek, Namibia

Received 16 August 2024
Revised 16 December 2024
20 February 2025
8 April 2025
Accepted 19 April 2025

Abstract

Purpose – This study aims at investigating the ways in which resilience to livelihood stressors (shocks, displacement risk and seasonality) could influence sustainable livelihoods outcomes (improved well-being) of national park-adjacent communities in Uganda.

Design/methodology/approach – With a sample of 364 respondents, data were obtained using a questionnaire survey and analyzed using structural equation modeling – with the aim of establishing the influence of resilience of national park-adjacent communities on their livelihood outcomes.

Findings – The results show that resilient to shocks and seasonality are the most crucial factors in enhancing the livelihoods of national park-adjacent communities. Building community members' resilience to shocks and seasonality has been shown to significantly improve the livelihoods of people residing near national parks in Uganda.

Originality/value – This paper expands the sustainable livelihood literature through an understanding of vulnerable national park-adjacent communities and stresses the influence of resilience to stressors on their livelihood outcomes. The research emphasizes the importance of enhancing community members' livelihoods with a sharp focus on resilience to shocks and seasonality by integrating resilience strategies into tourism and livelihood policies.

Keywords Resilience to shocks, Resilience to displacement risk, Resilience to seasonality, Sustainable livelihood outcome (improved well-being), National park-adjacent communities

Paper type Research paper

1. Introduction

Tourism plays a pivotal role in the global economy, accounting for approximately 9.1% of global gross domestic product (GDP) and 10% of global employment ([World Travel and Tourism Council, 2023](#)). In developing countries, tourism acts as a major driver of socioeconomic change ([Holland *et al.*, 2022](#)). Specifically, in Sub-Saharan Africa, Uganda has emerged as a destination offering rich nature-based and culturally diverse experiences ([World](#)

© Michelle Kiconco, Kassim Alinda, Immaculate Mary Mbabazi, James Mutabazi and Cynthia Kauami Ngunoue. Published in *Journal of Humanities and Applied Social Sciences*. Published by Emerald Publishing Limited. This article is published under the Creative Commons Attribution (CC BY 4.0) licence. Anyone may reproduce, distribute, translate and create derivative works of this article (for both commercial and non-commercial purposes), subject to full attribution to the original publication and authors. The full terms of this licence may be seen at <http://creativecommons.org/licences/by/4.0/legalcode>



Bank, 2022). In Uganda, tourism contributes 3.64% to the national GDP and provides 14.7% of total employment, underscoring its critical role in the country's development (UBOS, 2023). This growth in tourism is closely tied to the country's national parks, which play an integral role in sustaining Uganda's biodiversity and cultural heritage (Yu *et al.*, 2020). More so, national parks are increasingly promoted as a means of linking biodiversity conservation with local community livelihoods (Stone *et al.*, 2022), based on the idea that conservation and socioeconomic development can reinforce each other. With the growth of wildlife and nature-based tourism, many nations view national parks as a crucial revenue source, while local communities see them as a path to economic improvement. National parks are expected to generate benefits for nearby communities – within a 5 km radius – including fostering business development, creating employment, boosting incomes and enhancing infrastructure (Estifanos *et al.*, 2020). These communities are essential for balancing conservation goals with sustainable development, as they often rely on park resources for their livelihoods (MacKenzie *et al.*, 2017). In contrast, traditional conservation models that exclude park-adjacent communities may limit future land-use options and deprive them of income alternatives (Anaya and Espírito-Santo, 2018), underscoring the need for a more inclusive approach that involves these communities in both conservation and tourism development.

The Sustainable Livelihood Framework (SLF) is essential for understanding the livelihood dynamics of communities near national parks, where tourism often serves as a primary income source. While the SLF literature extensively addresses livelihood assets, strategies and institutional processes (Habib *et al.*, 2023), less attention has been given to how the vulnerability context – especially related to tourism – affects livelihood outcomes. Most existing studies on vulnerability have focused on climate-induced risks, such as Kumar *et al.* (2020) on smallholder adaptation to climatic changes and Saifullah *et al.* (2021) on the well-being of Indigenous communities in Malaysia, but these overlooked key dimensions of vulnerability, such as shocks, trends and seasonality. Moreover, few studies have explored the vulnerability of communities living near national parks, where livelihoods are closely linked to tourism (Liu *et al.*, 2020). While tourism diversifies income and reduces agricultural dependence, it can also exacerbate income inequality, strain ecosystems and intensify seasonal pressures, leading to overcrowding during peak periods and low activity during the off-season (Zhang *et al.*, 2024). Additionally, displacement and restricted access to resources, particularly for indigenous groups, undermine the long-term sustainability of these livelihoods (Mizrahi *et al.*, 2019). Like many African nations, Uganda's park-adjacent communities often face extreme poverty, with some of the most marginalized groups residing in close proximity to protected areas. A notable example is the Batwa, an Indigenous group near Bwindi Impenetrable National Park, who experience severe poverty, earning an average of just US \$0.26 per day (Kokunda *et al.*, 2023). Despite extensive research on the relationship between tourism and poverty, there is a noticeable lack of focus on sustainable livelihoods, resilience knowledge and the implementation of best practices in managing local natural resources, enhancing sustainability and developing mitigation strategies in Uganda. This creates a significant academic gap that this study aims to address.

To address this gap, vulnerability assessment is necessary to determine how and why park-adjacent communities in Uganda are susceptible to adverse impacts, while examining resilience focuses on how these communities adapt to vulnerabilities and recover from stressors (Sisneros-Kidd *et al.*, 2019). By understanding these dynamics, relevant organizations can better design strategies that not only support immediate responses to vulnerabilities but also build long-term resilience, creating conditions for communities to cope proactively. Consequently, by adopting an integrated livelihood analysis approach to sustainable tourism, this research will contribute to the existing body of knowledge on sustainable livelihoods by identifying the root causes of declining livelihoods in these regions. Additionally, it will propose resilience-based strategies to improve the well-being of local communities. The findings are expected to contribute valuable insights that can inform policy and development initiatives aimed at fostering sustainable livelihoods and enhancing resilience in similar contexts across Africa, aligning with the goal of eradicating poverty (SDG1).

The primary research question of this study is: *Does resilience to vulnerabilities impact the livelihoods of communities living near national parks?* To address this, the study has two key objectives. Firstly, to explore how resilience to shocks, displacement risks and seasonal variability influences the sustainable livelihood outcomes (improved well-being) of park-adjacent communities. Secondly, to suggest the resilience strategies these communities can employ to navigate their unique vulnerabilities. The rest of this paper is organized as follows: [Section 2](#) reviews the existing literature and develops hypotheses. [Section 3](#) details the research methodology, [Section 4](#) presents the findings and [Section 5](#) discusses the results. The last section highlights key conclusions and suggests directions for future research.

2. Literature review and hypothesis development

2.1 Study setting

Uganda's national park history began in the 1950s with informal conservation strategies that involved displacing indigenous communities who relied on these lands for their livelihoods, leading to poverty and deprivation (Solberg, 2022). Early conservation efforts lacked formal policies or institutional support, with the government providing occasional game meat to displaced residents (Ashaba, 2024). This system persisted until political instability in 1971, which caused the collapse of conservation efforts (Ahebwa *et al.*, 2012). After the National Resistance Movement (NRM) restored stability in 1986, efforts to revitalize national parks began. However, communities living near parks were excluded from conservation benefits, relying on vulnerable subsistence agriculture with limited economic returns (Ashaba, 2024), leading to marginalization and conflicts.

2.2 Theoretical anchoring

This study uses the SLF to explore sustainability, as it effectively captures the vulnerability context in which communities operate (Scoones, 1998). The SLF considers external shocks, stresses and trends that impact livelihoods, providing valuable insights into how communities can build resilience. However, a key limitation of the SLF is its static nature, which may lead to the resurgence of traditional poverty measures based on income, well-being and capabilities. Although the SLF emphasizes non-income aspects, such as reduced vulnerability, the difficulty in measuring these outcomes, coupled with the reliance on subjective resilience assessments tied to unpredictable future events, can undermine its effectiveness and reduce its utility in development activities (Small, 2007).

Furthermore, the SLF traditionally focuses on analyzing livelihoods within relatively stable structures of assets, strategies and outcomes. This static perspective does not fully capture the dynamic and evolving nature of livelihoods, particularly in communities surrounding national parks, where livelihoods are influenced by rapid environmental, economic and social changes. For instance, developments in tourism or shifts in conservation policies can significantly affect local economies, creating both opportunities and risks. Phuong *et al.* (2024) argue that the SLF fails to adequately address the fluidity of livelihoods in resource-dependent areas. To mitigate this limitation, the framework could be adapted to include a temporal dimension, recognizing how livelihoods evolve in response to short-term shocks and long-term stresses. Incorporating the concept of livelihood resilience would allow the SLF to better account for how communities adapt to tourism-induced changes and other dynamic factors.

In addition, while the SLF does analyze vulnerability, it tends to focus on isolated environmental risks and overlooks the interconnected nature of vulnerabilities faced by communities. Vulnerability is influenced not only by environmental factors, such as climate change, but also by socioeconomic and political elements, including financial risk and social exclusion (Eriksen *et al.*, 2021). To address this, the SLF could benefit from integrating a systems theory approach to vulnerability, recognizing that shocks in one system (e.g. tourism disruptions) can have cascading effects on others, such as health or general well-being. This

broader, systemic understanding would enable more effective, holistic policy interventions to support communities living near national parks.

2.2.1 Sustainable livelihood outcome (improved well-being). According to [Natarajan et al. \(2022\)](#), sustainable livelihood outcomes aim to enhance income, food resources and future prospects while promoting long-term environmental, social and economic development. The *SLF* identifies key outcomes such as increased job opportunities, poverty reduction, improved well-being and sustainable resource management, emphasizing the multidimensional nature of well-being, which spans economic, social and psychological dimensions ([Kasim, 2019](#)). [Proctor \(2024\)](#) describes well-being in terms of material, social, psychological and subjective perceptions, while [Scoones \(1998\)](#) defines it as a people-centered approach that prioritizes security, happiness and empowerment alongside tangible factors like income, while [Kimengsi et al. \(2020\)](#) highlight well-being as encompassing income, consumption, health, security and environmental sustainability, which are essential for resilience. [Saifullah et al. \(2021\)](#) underscore its importance in assessing sustainable livelihoods, particularly through the subjective experiences of individuals. In sum, well-being is a multifaceted concept that integrates both quantitative factors like income and qualitative aspects such as empowerment, happiness and stress management, forming a comprehensive framework for assessing sustainable livelihoods.

2.2.2 Vulnerability context and resilience. On one hand, vulnerability refers to a system's susceptibility to disturbance events, influenced by factors like exposure, sensitivity and adaptive capacity. Exposure indicates the risk a system faces from natural disasters, sensitivity measures how much a system is impacted based on its characteristics and adaptive capacity is the ability to recover from disturbances ([Tsao and Ni, 2016](#)). On the other hand, resilience, though widely used in human and environmental studies, lacks a universally accepted definition. Literature identifies three main dimensions: (1) stability or buffering capacity, which refers to the system's threshold before significant change or collapse; (2) recovery or rebound capacity, which focuses on returning to the original state after a disturbance, emphasizing recovery time and (3) transformation or creation capacity, highlighting the ability to adapt and leverage new opportunities for development ([Wilson et al., 2018](#)). Resilience or adaptive capacity, is crucial for communities to recover from environmental shocks, involving processes like self-organization and adaptation that reduce vulnerability and ensure sustainability.

Scholars [Wilson et al. \(2018\)](#) argue that communities are most resilient when their social, economic, cultural, political and environmental domains are well-developed. Conversely, underdeveloped domains increase vulnerability, especially in communities near national parks, which face disturbances such as natural disasters, displacement and tourism seasonality. These factors worsen socioeconomic inequalities and disrupt livelihoods ([Dube et al., 2023](#)). Limited resources and coping mechanisms deepen these vulnerabilities, making it harder for poorer communities to recover. Resilient communities can buffer shocks, preserve structures and adapt or reorganize within their existing systems, sometimes even undergoing radical transformation ([Wilson et al., 2018](#)). Vulnerability and resilience overlap, with communities that have lower exposure and sensitivity being more stable and better able to withstand shocks, while those with higher vulnerability struggle. Based on this literature, the following hypotheses are developed.

2.3 Hypothesis development

2.3.1 Resilience to shocks and sustainable livelihood outcome (improved well-being). Communities near national parks in Uganda face significant challenges that threaten their agricultural livelihoods and overall well-being. Human-wildlife conflict, particularly with elephants in areas like Murchison Falls National Park, disrupts farming by damaging crops and attacking livestock ([MacKenzie et al., 2017](#); [Oniba and Robertson, 2019](#)). Rapid population growth and restricted access to park resources exacerbate these tensions,

leading some to encroach on parklands for survival. Agriculture, which supports over 80% of the local population, is also highly vulnerable to climate variability, with fluctuating rainfall, droughts and poor harvests contributing to food insecurity (Labbe *et al.*, 2016). Unpredictable weather also affects tourism, which is a key economic activity, by disrupting activities like gorilla tracking (Kilungu *et al.*, 2019). Health issues further compound these challenges, with poor access to clean water and high rates of diseases like malaria and typhoid (Muylaert *et al.*, 2021). Resilience to these shocks – such as climate change, health crises and human–wildlife conflict – is enhanced by access to information and safety nets, which improve preparedness and support sustainable livelihoods (Nyström, 2018). Given these challenges, further research is needed to explore how resilience to these vulnerabilities improves livelihoods in Uganda’s context. Therefore, we hypothesize that

H1. Resilience to shocks positively influences sustainable livelihood outcomes (improved well-being of national park-adjacent communities).

2.3.2 Resilience to displacement risk and sustainable livelihood outcome (improved well-being). Rodriguez (2021) highlights that displacement from national parks severely affects those dependent on park resources, often leaving them struggling to find new economic opportunities. Conservation efforts, particularly in India, have led to the enclosure of forests and commons that impoverished communities, including indigenous people and Adivasis, rely on for sustenance and income (Kabra, 2020). This has led to “green grabbing,” where these populations are evicted from protected areas under the guise of biodiversity conservation, increasing their vulnerability and pushing them into exploitative labor systems (Büscher and Fletcher, 2018).

In Uganda, the challenges are evident from the poorly executed and violent evictions at Mount Elgon National Park, which displaced about 30,000 individuals without compensation for land, crops or homes (Vedeld *et al.*, 2016). Similarly, resettlement in Zesui parish to less fertile lands like Bukwo has led to continued encroachment on park resources (Vedeld *et al.*, 2016). Larsen (2018) notes the social impacts of displacement, such as disrupted communal bonds and loss of cohesion. In contrast, the Xingu Kaiabi in the Brazilian Amazon have demonstrated greater resilience through leadership, financial support and adaptive strategies like reciprocity networks, political leadership and community-based resource management (Athayde and Silva-Lugo, 2018). Sina *et al.* (2019) posits that successful displacement management, including re-employment and proper resettlement, can improve livelihood outcomes and enhance well-being. Therefore, this study hypothesizes that

H2. Resilience to displacement risk positively influences sustainable livelihood outcomes (improved well-being) of national park-adjacent communities.

2.3.3 Resilience to seasonality and sustainable livelihood outcome (improved well-being). Seasonality in tourism presents major challenges to sustainable livelihoods, as Rongna and Sun (2020) define it as a temporal imbalance affecting aspects like visitor numbers, spending, transportation, employment and attraction admissions. This issue is particularly acute for communities reliant on national parks, where tourism fluctuates between peak and off-peak seasons. Peak seasons bring high visitor rates and intense tourism activity, straining natural resources, disturbing wildlife and causing environmental degradation (Martínez *et al.*, 2019). In contrast, off-peak seasons see lower tourism demand, leading to reduced employment stability and diminished profits for local communities. Kumar *et al.* (2020) found that resilience strategies, such as safety nets, price stabilization funds and alternative employment, can improve well-being. Thus, we hypothesize that

H3. Resilience to seasonality positively influences sustainable livelihood outcomes (improved well-being) of national park-adjacent communities.

3. Methodology

3.1 Design, population and sample

This study employed a cross-sectional, quantitative research design to examine the relationship between resilience to vulnerabilities and sustainable livelihood outcomes. A cross-sectional approach allowed for data collection at a specific point in time, enhancing the credibility and applicability of the findings. Quantitative methods were chosen to draw generalizable conclusions from a representative sample, as guided by [Creswell and Plano Clark \(2023\)](#). The study targeted members of the Uganda Community Tourism Association (UCOTA), a non-profit organization of individuals living near national parks in Uganda's Western Region, which includes Bwindi, Queen Elizabeth and Kibale National Parks. The study focused on UCOTA because it houses the highest number of community members adjacent to national parks. The western region was chosen because tourism in Uganda is predominantly concentrated in this area, with the country's three most visited national parks located in the southwestern part as well as significant human settlements on the borders of these parks ([Adiyia et al., 2017](#)). A sample of 364 respondents was selected from a population of 2,121, following the sample size recommendations of [Hair et al. \(2014\)](#), [Yamane \(1973\)](#) and the Raosoft calculator. A proportionate stratified sampling technique was used to define the sampling frame and to ensure that all strata are sampled at the same rate ([Lynn, 2019](#)), followed by simple random sampling within each stratum to ensure randomness ([Saunders and Townsend, 2018](#)). Respondents were randomly chosen using unique identification numbers until the sample size of 364 was achieved ([Saunders and Townsend, 2018](#)).

3.2 Questionnaire and variables measurement

Data were collected using a structured questionnaire with closed-ended questions, developed from a comprehensive literature review. A five-point Likert scale, ranging from "strongly disagree" to "strongly agree," was used to quantify responses, offering clarity and simplicity ([Tanujaya et al., 2022](#)). A pilot test with 25 participants from the targeted population was conducted to address potential issues and increase validity and reliability of self-reported data. To address literacy barriers, trained research assistants administered the questionnaires orally and simplified the language and formats to avoid issues of misinterpretation of scales and limited comprehension. The study achieved a 100% response rate, with 364 valid questionnaires submitted.

Independent and dependent variables were operationalized based on the review of literature. Resilience to shocks, including climate change, human-wildlife conflict and health issues, was measured using seven items adapted from [Jones and Tanner \(2015\)](#) and [Masud et al. \(2016\)](#). Resilience to displacement risk was evaluated with four items based on [Lohmann \(2015\)](#), [Wilson and Secker \(2015\)](#) and others. Resilience to seasonality, reflecting adaptation to tourism fluctuations, was assessed with eleven items ([Lohmann, 2015](#); [Masud et al., 2016](#)). Sustainable livelihood outcomes, encompassing security, self-esteem, happiness, income and stress levels, were operationalized as improved well-being ([Dodge et al., 2012](#)).

The data were analyzed using SPSS version 23.0 for organization, cleaning and preliminary analysis to ensure accuracy and completeness. IBM AMOS version 27.0 was then used for advanced statistical modeling. According to [Mia et al. \(2019\)](#), AMOS is preferred for measuring management constructs. It is a covariance-based tool that assumes normality, linearity and no outliers, conditions met by the data, ensuring the study's findings' reliability and integrity.

4. Results

4.1 Demographic characteristics

[Table 1](#) illustrates that the majority of respondents (59.2%) were female, with 185 female participants compared to 179 male respondents. This gender distribution is critical for

Table 1. Demographic profile of respondents

Variable	Category	Frequency	Percentage %
<i>Gender</i>	Male	179	49.2
	Female	185	50.8
	<i>Total</i>	<i>364</i>	<i>100</i>
<i>Age</i>	18–24	32	8.8
	25–29	68	18.7
	30–34	66	18.1
	35–39	38	10.4
	40–44	41	11.3
	45–49	37	10.2
	50–54	36	9.9
	55–59	45	12.4
	60 and above	1	0.3
	<i>Total</i>	<i>364</i>	<i>100</i>
<i>Income</i>	Less than 100,000	195	53.6
	100,001–200,000	104	28.6
	200,001–300,000	31	8.5
	300,001–400,000	15	4.1
	400,001 and above	7	1.9
	Prefer not to say	12	3.3
	<i>Total</i>	<i>364</i>	<i>100</i>
<i>Income source</i>	Salary	36	9.9
	Wage	92	25.3
	Income from own business	190	52.2
	Pension	2	0.5
	Cash transfer from relatives	5	1.4
	Donations	16	4.4
	Others	23	6.3
	<i>Total</i>	<i>364</i>	<i>100</i>
	<i>Education level</i>	Postgraduate degree	5
Bachelor's degree		10	2.7
Diploma		32	8.8
A' level/technical education		29	8.0
O' level		71	19.5
Primary education		150	41.2
No formal schooling		67	18.4
<i>Total</i>		<i>364</i>	<i>100</i>

Source(s): Primary data

understanding the dynamics of sustainable livelihoods, as it highlights how gender can influence livelihood outcomes. Research by [Kasie et al. \(2018\)](#) indicates that female-headed households are particularly vulnerable during shocks, as they typically have fewer resources and limited adaptive capacity compared to male-headed households. This underscores the need for gender-specific interventions that can help women better cope with economic and environmental challenges. Moreover, the dominant age group of respondents, 25–29 years, is particularly significant, as individuals in this age bracket are often focused on career development and exploring new opportunities. This stage of life is typically associated with greater adaptability and innovation, qualities that are essential for building resilience in the face of challenges. Regarding income, most respondents reported monthly earnings of less than 100,000 UGX, which is equivalent to roughly 3,000 UGX per day (at an exchange rate of 1 USD = 3,700 UGX). For many, the primary source of income was self-employment, with 190 individuals identifying their own businesses as their main livelihood activity. Additionally, a significant portion of the respondents (150 individuals) had only basic

education, corresponding to primary school completion. According to the [World Bank \(2022\)](#), extreme poverty is defined as living on less than \$1.90 per day. These demographic characteristics support anecdotal evidence suggesting that communities near national parks are living below the poverty line, with daily earnings falling below \$1.90 and limited access to higher education.

4.2 Factor structure of resilience and sustainable livelihood outcome – improved well-being

Exploratory factor analysis (EFA) was conducted to assess the factor structure of the variables and determine if the items measured specific constructs ([Hair et al., 2014](#)). This analysis helped identify which items evaluating resilience and sustainable livelihood outcomes should be included for further analysis. The results, presented in [Table 2](#), show the factor loadings for all items. Except for three items (SLWB1, SLWB2 and SLWB6), all items related to improved well-being and resilience had satisfactory loadings (>0.4) and were retained for further analysis ([Saunders and Townsend, 2018](#)).

4.3 Confirmatory factor analysis

CFA was conducted to assess whether the data fit a theoretical model and to verify the factor structure of the observed variables ([Hair et al., 2014](#)). One item measuring resilience to seasonality (VCRS2) was excluded due to low factor loadings (<0.05) and four items (SLWB3, SLWB8, SLWB9 and SLWB13) were excluded at this stage due to low communality (<0.05), as they were not well represented by the extracted factors, thus indicating poor measurement quality. Goodness-of-fit indices (Chi-square/df < 3, Incremental fit index (IFI), Tucker–Lewis index (TLI), comparative fit index (CFI) >0.90 and root mean square error of approximation (RMSEA) <0.08) indicated a satisfactory model fit, aligning with established guidelines.

The measurement model was evaluated for internal consistency reliability, convergent validity and discriminant validity. Composite reliability (CR) confirmed internal consistency, with all constructs exceeding the 0.7 threshold ([Nunnally, 1978](#)). Factor loadings for all items were above 0.5, indicating adequate convergent validity, with average variance extracted (AVE) values ranging from 0.569 to 0.675. Discriminant validity was confirmed as the square roots of AVE exceeded the intercorrelation values between constructs ([Cheung et al., 2023](#)). Overall, the study's constructs demonstrated satisfactory reliability and validity, as shown in [Table 3](#).

4.4 Structural model specification

Following the development of the hypothesized model, which included latent variables, refinements were made to improve the model, as described in the CFA. [Table 4](#) shows the final manifest variables chosen for the structural equation modeling (SEM) analysis.

4.5 Structural equation modelling – SEM

SEM was the primary statistical method used to test the hypotheses in this study. SEM is a powerful analytical tool for examining complex relationships among latent variables and assessing causal pathways within the conceptual model. It allows for the simultaneous estimation of measurement errors and the modeling of relationships between latent constructs, making it ideal for hypothesis testing and theory validation in behavioral research ([Cheung et al., 2023](#)).

By using SEM, we aimed to uncover the mechanisms driving the relationships between resilience and sustainable livelihood outcomes, evaluate the direct effects among key constructs and gain insights into the causal pathways at play. SEM's ability to integrate theory with statistical analysis aligns with recent advancements in empirical research, offering a

Table 2. Factor structure –resilience and sustainable livelihood outcome – improved well-being

Codes	Items	Factor loadings
<i>Resilience to shocks (VCRSH)</i>		
VCRSH1	I am prepared to deal with natural shocks (e.g. landslides, floods and droughts) if they occur in the national park-adjacent community where I live or work	0.850
VCRSH2	I have devised an emergency plan to deal with health-related shocks (illnesses and epidemics) if they occur in the national park-adjacent community where I live or work	0.905
VCRSH3	I can still find alternative sources of income amidst natural disasters and/or health-related epidemics if they occur in the national park-adjacent community where I live or work	0.819
VCRSH4	I have access to sufficient financial resources to ensure that I recover from the threats posed by natural disasters and/or health-related epidemics	0.620
VCRSH5	I regularly save money from my income to deal with financial crises	0.524
<i>Resilience to displacement risk (VCRD)</i>		
VCRD1	I will receive adequate compensation to enable me to relocate in case I lose my property due to tourism-related development in the national park-adjacent community where I live/work	0.576
VCRD2	I can easily find work opportunities if I am displaced from the national park-adjacent community where I live/work	0.952
VCRD3	I would still find a sense of belonging if I am displaced from the national park-adjacent community where I live/work	0.873
VCRD4	If displacement from the national park community where I live/work was to occur, my household would be able to draw on the support of family and friends to ensure that we recover	0.687
<i>Resilience to seasonality (VCRS)</i>		
VCRS1	I can find alternative employment during the off-peak tourism seasons in the national park-adjacent community where I live/work	0.705
VCRS2	I am engaged in multiple income-generating activities to cater for seasonal changes in tourism (peak and off-peak seasons) in the national park-adjacent community where I live/work	0.697
VCRS3	I can devise means of paying for basic utilities (water/electricity) in case of price fluctuations due to seasonal changes in tourism in the national park-adjacent community where I live/work	0.406
VCRS4	I am able to buy food for my household even when there is less demand for tourism products in the national park-adjacent community where I live/work	0.885
VCRS5	I can devise means of providing adequate health care for members of my household in case of less demand for tourism products in the national park-adjacent community where I live/work	0.843
VCRS6	I devise means of providing for the education of members of my household in case of less demand for tourism products in the national park-adjacent community where I live/work	0.678
<i>Sustainable livelihood outcome (improved well-being) (SLWB)</i>		
SLWB3	I feel hopeful about the future	0.555
SLWB4	I feel safe from violence at home	0.676
SLWB5	I feel safe from violence in the park-adjacent community where I live/work	0.652
SLWB7	I have access to adequate means of communication in the national park-adjacent community where I live/work	0.546
SLWB8	I feel able to live my life the way I want	0.599
SLWB9	I enjoy my personal life	0.790
SLWB10	I am happy with the quality of my sleep	0.732
SLWB11	I am happy with the state of my physical health	0.831
SLWB12	I have no problem with my mental health	0.629
SLWB13	I contribute to and have some control over community life	0.541
SLWB14	I am happy with my friendships and personal relationships	0.817
SLWB15	I am able to ask someone for help in case I have a problem	0.773

Source(s): Primary data

Table 3. CFA, validity and reliability results

Variable	Factor	Item code	Item loadings	Cronbach's alpha	Composite reliability (CR)	Average variance extracted	Discriminant validity \sqrt{AVE}
Resilience	<i>Resilience to shocks</i>	VCRSH1	0.69	0.858	0.902	0.675	0.822
		VCRSH2	0.83				
		VCRSH3	0.92				
		VCRSH4	0.70				
		VCRSH5	0.64				
	<i>Resilience to displacement risk</i>	VCRD1	0.64				
		VCRD2	0.87				
		VCRD3	0.85				
		VCRD4	0.69				
	<i>Resilience to seasonality</i> <i>VCRS6 0.82</i>	VCRS1	0.65				
		VCRS2	0.71				
		VCRS4	0.91				
		VCRS5	0.91				
		VCRS6	0.82				
		Sustainable livelihood outcome	<i>Improved well-being</i>				
SLWB5	0.67						
SLWB7	0.56						
SLWB10	0.68						
SLWB11	0.77						
SLWB12	0.65						
SLWB14	0.73						
SLWB15	0.71						

Source(s): Primary data

Table 4. Manifest variables used in SEM

Factor	Code	Measurement item
Resilience to shocks (VCRSH)	VCRSH1	I am prepared to deal with natural shocks (e.g. landslides, floods and droughts) if they occur in the national park-adjacent community where I live or work
	VCRSH2	I have devised an emergency plan to deal with health-related shocks (illnesses and epidemics) if they occur in the national park-adjacent community where I live or work
	VCRSH3	I can still find alternative sources of income amidst natural disasters and/or health-related epidemics if they occur in the national park-adjacent community where I live or work
	VCRSH4	I have access to sufficient financial resources to ensure that I recover from the threats posed by natural disasters and/or health-related epidemics
	VCRSH5	I regularly save money from my income to deal with financial crises
Resilience to displacement risk (VCRD)	VCRD1	I will receive adequate compensation to enable me to relocate in case I lose my property due to tourism-related development in the national park-adjacent community where I live/work
	VCRD2	I can easily find work opportunities if I am displaced from the national park-adjacent community where I live/work
	VCRD3	I would still find a sense of belonging if I am displaced from the national park-adjacent community where I live/work
	VCRD4	If displacement from the national park community where I live/work was to occur, my household would be able to draw on the support of family and friends to ensure that we recover
Resilience to seasonality (VCRS)	VCRS1	I can find alternative employment during the off-peak tourism seasons
	VCRS2	My household is prepared to cope with threats posed by climate changes in the national park-adjacent community where I live/work
	VCRS4	I am engaged in multiple income-generating activities to cater for seasonal changes in tourism (peak and off-peak seasons) in the national park-adjacent community where I live/work
	VCRS5	I can devise means of paying for basic utilities (water/ electricity) in case of price fluctuations due to seasonal changes in tourism in the national park-adjacent community where I live/work
	VCRS6	I am able to buy food for my household even when there is less demand for tourism products in the national park-adjacent community where I live/work
Sustainable livelihood outcomes (Improved well-being) (SLWB)	SLWB4	I feel able to do the things I choose to do
	SLWB5	I contribute to and have some control over community life
	SLWB7	I am able to ask someone for help in case I have a problem
	SLWB10	I feel safe from violence at home
	SLWB11	I have no problem with my mental health
	SLWB13	I feel able to live my life the way I want
	SLWB12	I have enough money to meet my needs
	SLWB14	I enjoy my personal life
SLWB15	I am happy with the quality of my sleep	

Source(s): Primary data

comprehensive view of the interactions within the study. Hair *et al.* (2014) emphasize SEM’s effectiveness in assessing relationships between multiple variables, making it a suitable choice for analyzing the dynamics of resilience and livelihood outcomes among park-adjacent communities. The findings from the SEM analysis are illustrated in Figure 1 below.

The findings from Table 5 were analyzed to assess the hypothesized relationship using the beta coefficient (β), test statistic (t) and associated p -value.

H1, which proposed a positive relationship between resilience to shocks and sustainable livelihood outcomes (i.e. improved well-being), demonstrated statistical significance ($\beta = 0.211$, $t = 2.278$, $p = 0.023$). The positive path coefficient (β) signifies a significant relationship and means that for every one-unit increase in resilience to shocks, there is a 0.211 increase in improved well-being, assuming all other variables are held constant. In addition, the calculated t -value exceeded the critical threshold of 1.96 and the p -value was less than 0.05, confirming support for hypothesis H1. These results suggest that resilience to various shocks – such as health shocks (e.g. pandemics), climate-related shocks (e.g. droughts or floods) and financial shocks – are positively and significantly associated with sustainable livelihood outcomes (improved well-being) of communities living adjacent to national parks in Uganda. This finding underscores the importance of preparedness in mitigating the adverse effects of such shocks.

H2: Resilience to displacement risk did not show a statistically significant impact on sustainable livelihood outcomes (improved well-being) ($\beta = 0.067$, $t = 0.941$, $p = 0.345$),

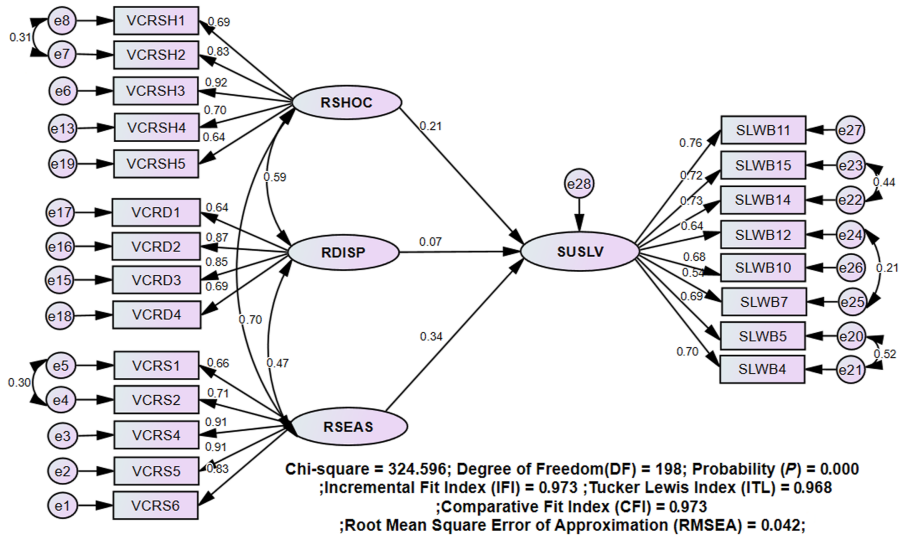

Figure 1. Structural model. Source: AMOS 7.0 output for this study

Table 5. Standardized estimates of the model for hypothesis testing

		B	S.E.	β	C.R.(t)	p	Verdict
SUSLV	← RSHOC	0.132	0.058	0.211	2.278	0.023	Supported
SUSLV	← RDISP	0.047	0.050	0.067	0.941	0.347	Not supported
SUSLV	← RSEAS	0.236	0.059	0.345	3.995	***	Supported

Note(s): *** $p < 0.01$

Source(s): Results from AMOS 7.0 output for this study

leading to the rejection of hypothesis H2. The path coefficient (β) indicates that for each one-unit increase in resilience to displacement risk, improved well-being would increase by 0.067; however, this value is relatively small, indicating that even if the relationship were significant, the effect size would be minor. Besides, the t -value (0.941) was well below the critical value of 1.96 and the p -value exceeded the significance threshold of 0.05, suggesting that resilience to displacement risk does not significantly influence well-being in this study's context. This finding may indicate that factors related to displacement risk have a less pronounced effect on livelihood outcomes than initially expected, possibly due to the moderating influence of other unaccounted variables, such as social support or alternative livelihood strategies. It may also reflect the specific characteristics of the study population, suggesting that resilience to displacement is less critical for well-being in this context than other settings. Further research is needed to explore the role of displacement risk in different contexts, particularly where displacement is more frequent or severe or where alternative resilience strategies are more accessible.

H3: The relationship between resilience to seasonality and sustainable livelihood outcomes (improved well-being) was found to be significant ($\beta = 0.345$, $t = 3.995$, $p < 0.01$). The path coefficient (β) of 0.345 suggests that for a unit increase in resilience to seasonality, there is a 0.345 increase in improved well-being, assuming all other variables are held constant. The positive value of β indicates that as resilience to seasonality increases, improved well-being also increases. This is a moderate effect size, meaning that resilience to seasonality has a noteworthy positive impact on well-being. Additionally, given that the t -value exceeds 1.96 and $p < 0.05$, hypothesis H3 was supported. This indicates that resilience strategies aimed at addressing seasonality – such as securing alternative employment and income sources to meet basic needs during off-peak seasons – can significantly enhance the well-being of park-adjacent communities. This finding highlights the importance of developing strategies to mitigate the impacts of seasonality, such as product diversification, hosting events and festivals, implementing price differentiation and exploring market segmentation during off-peak periods.

5. Discussion of findings

First, the significant relationship between resilience to shocks and improved well-being aligns with [Smith et al. \(2021\)](#), who found that the livelihoods of park-adjacent communities in South Africa were threatened by the COVID-19 shock, which reduced tourism revenues and halted employment. This suggests that communities with greater preparedness for such shocks experience better livelihood outcomes. This supports findings by [Sok and Yu \(2015\)](#), who found that resilience to floods, droughts and economic crises improves well-being and aligns with [Chaigneau et al. \(2022\)](#) and [Beauchamp et al. \(2021\)](#), who emphasized that resilience directly enhances livelihood outcomes. In these communities, mitigating risks from health, economic and conflict-related shocks can lead to better well-being. Preparedness to adapt to these shocks, such as using climate-smart technologies like improved crop varieties and livestock breeds, can enhance livelihoods. Additionally, anticipating economic shocks encourages households to adopt risk management strategies, such as saving and buffer stocks, as confirmed by [Kasie et al. \(2018\)](#).

Second, the finding that resilience to displacement risk does not enhance livelihood sustainability contradicts studies by [Pomarico \(2017\)](#), who highlights the challenges of conservation-induced displacement in West Africa, where the lack of alternative livelihoods and resources in resettlement areas worsens socioeconomic difficulties for park-adjacent communities. Despite settlement bans within the park, inadequate support forces some displaced farmers to illegally enter at night for food. Similarly, [MacKenzie et al. \(2017\)](#) examine displacement in Brazil, citing unresolved compensation, unaddressed community concerns (such as land value and park objectives) and bureaucratic obstacles, which hinder resettlement and further erode displaced livelihoods. In this study,

communities may not perceive displacement as a significant threat, the dynamics of displacement vary by geography, socio-political context and ecology. In regions where displacement is more frequent or severe – due to natural disasters, conflict or land-use changes – strategies like land allocation, income diversification and relocation support are crucial. The effectiveness of these strategies depends on governance frameworks. In areas with stronger legal and institutional frameworks for resettlement, resilience to displacement may have a greater impact (Li, 2024). The study population’s specific characteristics, including the absence of recent displacement events, suggest that communities focus more on other risks, such as economic shocks or environmental degradation (Cottyn, 2018). This highlights the need for further research into how displacement resilience varies across contexts to inform policy on when and how displacement strategies should be prioritized.

Third, tourism seasonality also plays a significant role in shaping the livelihoods of national park-adjacent communities. For example, Matiku *et al.* (2020) highlight that seasonality limits the ability of tourism-dependent households to sustain year-round operations, thereby diminishing the livelihoods of park-adjacent communities in South Africa. As such, communities that build resilience to seasonality are better equipped to manage income fluctuations between peak and off-peak periods (Kumar *et al.*, 2020). Households with strategies for low-income seasons are better able to meet essential needs such as food, water, electricity and education. These findings align with Rongna and Sun (2020), who argue that preparedness for seasonality – through diversifying income sources, seeking alternative employment during off-peak periods and adopting strategies to manage basic needs – can significantly enhance livelihoods. Thus, the study underscores that effective strategies to generate income during off-peak seasons contribute to livelihood sustainability and well-being, suggesting that resilience to tourism seasonality is key to long-term stability for these communities.

6. Conclusions, implications and future research

This study aimed to assess the impact of resilience to shocks, displacement risks and seasonal variability on the sustainable livelihood outcomes of communities near national parks in Uganda. Surveying 364 UCOTA respondents, the study found that resilience to shocks and seasonality significantly improves livelihood outcomes. Using a survey of 364 respondents from UCOTA, the study found that resilience to both shocks and seasonality are significant predictors of improved livelihood outcomes for these communities. In light of these results, the study proceeds to address its second objective by outlining resilience strategies that park-adjacent communities can adopt to mitigate their unique vulnerabilities and enhance their resilience.

6.1 Theoretical implications

Evaluating the vulnerability and resilience of communities is a crucial step in sustainable livelihood analysis. However, measuring sustainable livelihood outcomes remains complex due to varying levels of resilience among households (Quandt, 2018). This study advances the theory of sustainable livelihoods by measuring outcomes through a combined approach of well-being analysis and resilience to vulnerabilities, specifically in communities adjacent to national parks in Uganda. By integrating resilience into livelihood assessments, this study contributes to the growing body of SLF literature, highlighting the dynamic interplay between vulnerability, resilience and well-being. It emphasizes the importance of adaptive strategies, such as leveraging alternative employment in off-peak seasons and savings in building resilience and improving livelihoods in park-adjacent communities. Furthermore, the study can be replicated in different contexts, given the varied ways in which communities experience and respond to vulnerabilities. This offers a

foundation for future research to refine and expand the application of the SLF in diverse socioeconomic and environmental settings.

6.2 Empirical implications

Recent frameworks and methods have been proposed to address livelihood and resilience, yet many remain empirically underexplored. A primary challenge in resilience research is the lack of a standardized, quantifiable approach to measuring resilience, as it is difficult to assess empirically (Quandt, 2018). Much of the existing literature has focused on agronomic or institutional factors (Lindstädt *et al.*, 2016), overlooking key vulnerabilities faced by park-adjacent communities, especially in tourism-dependent regions. This study addresses these gaps by evaluating sustainable livelihoods across three critical dimensions – exposure to shocks, displacement risk and seasonality – in national park-adjacent communities in Uganda. It represents one of the few quantitative analyses of resilience in this context, contributing significantly to the literature on resilience and sustainable livelihoods in tourism-dependent regions. By incorporating a more comprehensive set of indicators, this research enhances our understanding of how park-adjacent communities navigate vulnerabilities and adapt to shocks.

6.3 Practical and managerial implications

This study highlights the need to build resilience in national park-adjacent communities to improve livelihoods. UCOTA should focus on strengthening local resilience to natural disasters, health crises, economic disturbances and conflicts. A key strategy is creating a community risk register to identify potential shocks and develop contingency plans, such as food banks and emergency funds, for common crises like droughts and floods. Additionally, addressing seasonal tourism fluctuations through diversified offerings, events and year-round discounts will help stabilize income. Empowering low-income, low-literacy communities can further enhance resilience by encouraging small-scale businesses, such as local tourism guides, handicrafts and agricultural ventures, to reduce reliance on volatile sectors. Community-driven education programs in financial literacy and sustainable practices can increase adaptability. Finally, establishing social safety nets, such as savings groups or mutual support systems, will provide families with a cushion against economic shocks and unforeseen challenges, strengthening overall community resilience.

6.4 Policy implications

This study also highlights the need for national tourism policymakers to address shocks impacting national park-adjacent communities, in line with Uganda's NDP III and the UN SDGs. Policymakers should implement proactive measures such as collaborating with UCOTA, supporting community response teams and allocating tourism revenues for risk insurance to protect households and aid recovery. These strategies align with NDP III's focus on economic resilience, social protection and disaster management. Resource mapping, disaster planning and role assignments will enhance preparedness and contribute to SDG 1 (No Poverty). Training in disaster preparedness is also essential. Additionally, differential pricing and tax incentives for off-peak seasons will promote domestic tourism, stabilize revenue and support SDG 8 (Decent Work and Economic Growth).

6.5 Limitations and future research

This study has some limitations, including a sample limited to Uganda's western region and only UCOTA members – excluding other groups, which may affect the generalizability of the findings. Future research could consider other regions, use qualitative or mixed methods, longitudinal designs and comparative studies across industries and countries to gain deeper insights into resilience and sustainable livelihoods. These approaches would improve the robustness and relevance of resilience and livelihood research, enriching both theoretical and practical applications.

References

- Aidiya, B., Stoffelen, A., Jennes, B., Vanneste, D. and Ahebwa, W.M. (2017), "Analysing governance in tourism value chains to reshape the tourist bubble in developing countries: the case of cultural tourism in Uganda", in Novelli, M. (Ed.), *Ecotourism in Sub-Saharan Africa*, Routledge, pp. 19-35.
- Ahebwa, W.M., van der Duim, R. and Sandbrook, C. (2012), "Tourism revenue sharing policy at Bwindi Impenetrable National Park, Uganda: a policy arrangements approach", *Journal of Sustainable Tourism*, Vol. 20 No. 3, pp. 377-394, doi: [10.1080/09669582.2011.622768](https://doi.org/10.1080/09669582.2011.622768).
- Anaya, F.C. and Espírito-Santo, M.M. (2018), "Protected areas and territorial exclusion of traditional communities", *Ecology and Society*, Vol. 23 No. 1, art8, doi: [10.5751/ES-09850230108](https://doi.org/10.5751/ES-09850230108).
- Ashaba, I. (2024), "Historical roots of militarised conservation: the case of Uganda", in *Capitalism and Economic Crime in Africa*, Routledge, pp. 478-490.
- Athayde, S. and Silva-Lugo, J. (2018), "Adaptive strategies to displacement and environmental change among the Kaiabi indigenous people of the Brazilian Amazon", *Society and Natural Resources*, Vol. 31 No. 6, pp. 666-682, doi: [10.1080/08941920.2018.1426801](https://doi.org/10.1080/08941920.2018.1426801).
- Beauchamp, E., Sainsbury, N.C., Greene, S. and Chaigneau, T. (2021), "Aligning resilience and wellbeing outcomes for locally-led adaptation in Tanzania", *Sustainability*, Vol. 13 No. 16, p. 8976, doi: [10.3390/su13168976](https://doi.org/10.3390/su13168976).
- Büscher, B. and Fletcher, R. (2018), "Under pressure: conceptualizing political ecologies of green wars", *Conservation and Society*, Vol. 16 No. 2, pp. 105-113, doi: [10.4103/cs.cs_18_1](https://doi.org/10.4103/cs.cs_18_1).
- Chaigneau, T., Coulthard, S., Daw, T.M., Szaboova, L., Camfield, L., Chapin III, F.S., Gasper, D., Gurney, G.G., Hicks, C.C., Ibrahim, M. and James, T. (2022), "Reconciling well-being and resilience for sustainable development", *Nature Sustainability*, Vol. 5 No. 4, pp. 287-293, doi: [10.1038/s41893-021-00790-8](https://doi.org/10.1038/s41893-021-00790-8).
- Cottyn, I. (2018), "Livelihood trajectories in a context of repeated displacement: empirical evidence from Rwanda", *Sustainability*, Vol. 10 No. 10, 3521, doi: [10.3390/su10103521](https://doi.org/10.3390/su10103521).
- Creswell, J.W. and Plano Clark, V.L. (2023), "Revisiting mixed methods research designs twenty years later", in *Handbook of Mixed Methods Research Designs*, pp. 21-36.
- Dodge, R., Daly, A.P., Huyton, J. and Sanders, L.D. (2012), "The challenge of defining wellbeing", *International Journal of Wellbeing*, Vol. 2 No. 3, pp. 222-233, doi: [10.5502/ijw.v2i3.4](https://doi.org/10.5502/ijw.v2i3.4).
- Dube, K., Nhamo, G., Chikodzi, D. and Chapungu, L. (2023), "Mapping and evaluating the impact of flood hazards on tourism in South African national parks", *Journal of Outdoor Recreation and Tourism*, Vol. 43, 100661, doi: [10.1016/j.jort.2023.100661](https://doi.org/10.1016/j.jort.2023.100661).
- Eriksen, S., Schipper, E.L.F., Scoville-Simonds, M., Vincent, K., Adam, H.N., Brooks, N., Harding, B., Lenaerts, L., Liverman, D., Mills-Novoa, M., Mosberg, M., Movik, S., Muok, B., Nightingale, A., Ojha, H., Sygna, L., Taylor, M., Vogel, C. and West, J.J. (2021), "Adaptation interventions and their effect on vulnerability in developing countries: help, hindrance or irrelevance?", *World Development*, Vol. 141, 105383, doi: [10.1016/j.worlddev.2020.105383](https://doi.org/10.1016/j.worlddev.2020.105383).
- Estifanos, T.K., Polyakov, M., Pandit, R., Hailu, A. and Burton, M. (2020), "The impact of protected areas on the rural households' incomes in Ethiopia", *Land Use Policy*, Vol. 91, 104349, doi: [10.1016/j.landusepol.2019.104349](https://doi.org/10.1016/j.landusepol.2019.104349).
- Habib, N., Ariyawardana, A. and Aziz, A.A. (2023), "The influence and impact of livelihood capitals on livelihood diversification strategies in developing countries: a systematic literature review", *Environmental Science and Pollution Research*, Vol. 30 No. 27, pp. 69882-69898, doi: [10.1007/s11356-023-28192-0](https://doi.org/10.1007/s11356-023-28192-0).
- Hair, J.F., Gabriel, M. and Patel, V. (2014), "AMOS covariance-based structural equation modeling (CB-SEM): guidelines on its application as a marketing research tool", *Brazilian Journal of Marketing*, Vol. 13 No. 2, pp. 1-14, doi: [10.5585/remark.v13n2a4](https://doi.org/10.5585/remark.v13n2a4).
- Holland, K.K., Larson, L.R., Powell, R.B., Holland, W.H., Allen, L., Nabaala, M., Tome, S., Seno, S. and Nampushi, J. (2022), "Impacts of tourism on support for conservation, local livelihoods, and community resilience around Maasai Mara National Reserve, Kenya", *Journal of Sustainable Tourism*, Vol. 30 No. 11, pp. 2526-2548, doi: [10.1080/09669582.2021.1932927](https://doi.org/10.1080/09669582.2021.1932927).

-
- Jones, L. and Tanner, T. (2015), "Measuring 'subjective resilience': using people's perceptions to quantify household resilience", *Centre for Climate Change Economics and Policy, Working Paper No. 148*, Vol. 17, pp. 229-243, doi: [10.2139/ssrn.2643583](https://doi.org/10.2139/ssrn.2643583).
- Kabra, A., (2020), "Caste in stone? Exploring caste and class dimensions of conservation displacement in Central India", *Journal of Contemporary Asia*, Vol. 50 No. 5, pp.785-805, doi: [10.1080/00472336.2019.1696877](https://doi.org/10.1080/00472336.2019.1696877).
- Kasie, T.A., Adgo, E., Botella, A.G. and García, I.G. (2018), "Measuring resilience properties of household livelihoods and food security outcomes in the risky environments of Ethiopia", *Revista iberoamericana de estudios de desarrollo= Iberoamerican journal of development studies*, Vol. 7 No. 2, pp. 52-80, doi: [10.26754/ojs_ried/ijds.252](https://doi.org/10.26754/ojs_ried/ijds.252).
- Kasim, Y. (2019), "Impacts of livelihood assets on wellbeing of rural households in Northern Nigeria", *Journal of Engineering, Management, and Applied Sciences and Technologies*, Vol. 10 No. 17, pp. 1-8, doi: [10.31072/jemast.10.17.1](https://doi.org/10.31072/jemast.10.17.1).
- Kilungu, H., Leemans, R., Munishi, P.K., Nicholls, S. and Amelung, B. (2019), "Forty years of climate and land-cover change and its effects on tourism resources in Kilimanjaro National Park", *Tourism Planning and Development*, Vol. 16 No. 2, pp. 235-253, doi: [10.1080/21568316.2018.1483062](https://doi.org/10.1080/21568316.2018.1483062).
- Kimengsi, J.N., Mukong, A.K. and Balgah, R.A. (2020), "Livelihood diversification and household well-being: insights and policy implications for forest-based communities in Cameroon", *Society and Natural Resources*, Vol. 33 No. 7, pp. 876-895, doi: [10.1080/08941920.2019.1679066](https://doi.org/10.1080/08941920.2019.1679066).
- Kokunda, S., Nahabwe, H., Nahamya, J., Niwamanya, S., Mazirwe, R., Gougisa, S., Kemigisha, E. and Redvers, N. (2023), "Batwa Indigenous Peoples forced eviction for Conservation: A qualitative examination on community impacts", *PLOS Global Public Health*, Vol. 3 No. 8, e0002129, doi: [10.1371/journal.pgph.0002129](https://doi.org/10.1371/journal.pgph.0002129).
- Kumar, S., Mishra, A.K., Pramanik, S., Mamidanna, S. and Whitbread, A. (2020), "Climate risk, vulnerability and resilience: supporting livelihood of smallholders in semiarid India", *Land Use Policy*, Vol. 97, 104729, doi: [10.1016/j.landusepol.2020.104729](https://doi.org/10.1016/j.landusepol.2020.104729).
- Labbe, J., Ford, J.D., Berrang-Ford, L., Donnelly, B., Lwasa, S., Namanya, D.B., Twesigomwe, S. and Harper, S.L. (2016), "Vulnerability to the health effects of climate variability in rural southwestern Uganda", *Mitigation and Adaptation Strategies for Global Change*, Vol. 21 No. 6, pp. 931-953, doi: [10.1007/s11027-015-9643-4](https://doi.org/10.1007/s11027-015-9643-4).
- Larsen, A.L. (2018), "Forest for who? a minor field study exploring local narratives about Mghahinga Gorilla National Park, South-Western Uganda", available at: <https://lup.lub.lu.se/student-papers/search/publication/8944172> (accessed 5 May 2025).
- Li, S., (2024), "Community participation in ecological displacement from protected areas: a case study of giant panda national park, China", doi: [10.2139/ssrn.4962233](https://doi.org/10.2139/ssrn.4962233).
- Lindstädter, A., Kuhn, A., Naumann, C., Rasch, S., Sandhage-Hofmann, A., Amelung, W., Jordaan, J., Du Preez, C.C. and Bollig, M. (2016), "Assessing the resilience of a real world social-ecological system: lessons from a multidisciplinary evaluation of a South African pastoral system", *Ecology and Society*, Vol. 21 No. 3, p. 35, doi: [10.5751/ES08792210335](https://doi.org/10.5751/ES08792210335).
- Liu, W., Li, J., Ren, L., Xu, J., Li, C. and Li, S. (2020), "Exploring livelihood resilience and its impact on livelihood strategy in rural China", *Social Indicators Research*, Vol. 150 No. 3, pp. 977-998, doi: [10.1007/s11205-020-02347-2](https://doi.org/10.1007/s11205-020-02347-2).
- Lohmann, H. (2015), *Measuring Social Vulnerability and Adaptive Capacity to Climate Change in Dominican Republic Coastal Communities*, University of Rhode Island, doi: [10.2139/ssrn.2654872](https://doi.org/10.2139/ssrn.2654872).
- Lynn, P. (2019), "The advantage and disadvantage of implicitly stratified sampling", *Methods, data, analyses: A Journal for Quantitative Methods and Survey Methodology (Mda)*, Vol. 13 No. 2, pp. 253-266, doi: [10.12758/mda.2018.02](https://doi.org/10.12758/mda.2018.02).
- MacKenzie, C.A., Salerno, J., Hartter, J., Chapman, C.A., Reyna, R., Tumusiime, D.M. and Drake, M. (2017), "Changing perceptions of protected area benefits and problems around Kibale National

- Park”, Uganda”, *Journal of Environmental Management*, Vol. 200, pp. 217-228, doi: [10.1016/j.jenvman.2017.05.078](https://doi.org/10.1016/j.jenvman.2017.05.078).
- Martínez, J.M.G., Martín, J.M.M., Fernández, J.A.S. and Mogorrón-Guerrero, H. (2019), “An analysis of the stability of rural tourism as a desired condition for sustainable tourism”, *Journal of Business Research*, Vol. 100, pp. 165-174, doi: [10.1016/j.jbusres.2019.03.005](https://doi.org/10.1016/j.jbusres.2019.03.005).
- Masud, M.M., Al-Amin, A.Q., Junsheng, H., Ahmed, F., Yahaya, S.R., Akhtar, R. and Banna, H. (2016), “Climate change issue and theory of planned behaviour: Relationship by empirical evidence”, *Journal of Cleaner Production*, Vol. 113, pp. 613-623, doi: [10.1016/j.jclepro.2015.11.080](https://doi.org/10.1016/j.jclepro.2015.11.080).
- Matiku, S., Zuwarimwe, J. and Tshipala, N. (2020), “Community-driven tourism projects’ economic contribution to community livelihoods—a case of Makuleke Contractual Park Community Tourism Project”, *Sustainability*, Vol. 12 No. 19, 8230, doi: [10.3390/su12198230](https://doi.org/10.3390/su12198230).
- Mia, M.M., Majri, Y. and Rahman, I.K.A. (2019), “Covariance based-structural equation modeling (CB-SEM) using AMOS in management research”, *Journal of Business and Management*, Vol. 21 No. 1, pp. 56-6, doi: [10.9790/487X-2101025661](https://doi.org/10.9790/487X-2101025661).
- Mizrahi, M.I., Diedrich, A., Weeks, R. and Pressey, R.L. (2019), “A systematic review of the socioeconomic factors that influence how marine protected areas impact on ecosystems and livelihoods”, *Society & Natural Resources*, Vol. 32 No. 1, pp. 4-20, doi: [10.1080/08941920.2018.1489568](https://doi.org/10.1080/08941920.2018.1489568).
- Muylaert, R.L., Davidson, B., Ngabirano, A., Kalema-Zikusoka, G., MacGregor, H., Lloyd Smith, J.O., Fayaz, A., Knox, M.A. and Hayman, D.T. (2021), “Community health and human animal contacts on the edges of Bwindi Impenetrable National Park, Uganda”, *PLoS One*, Vol. 16 No. 11, e0254467, doi: [10.1371/journal.pone.0254467](https://doi.org/10.1371/journal.pone.0254467).
- Natarajan, N., Newsham, A., Rigg, J. and Suhardiman, D. (2022), “A sustainable livelihoods framework for the 21st century”, *World Development*, Vol. 155, 105898, doi: [10.1016/j.worlddev.2022.105898](https://doi.org/10.1016/j.worlddev.2022.105898).
- Nunnally, J.C. (1978), “An overview of psychological measurement”, in *Clinical Diagnosis of Mental Disorders: A Handbook*, pp. 97-146.
- Nyström, K. (2018), “Regional resilience to displacements”, *Regional Studies*, Vol. 52 No. 1, pp. 4-22, doi: [10.1080/00343404.2017.1335368](https://doi.org/10.1080/00343404.2017.1335368).
- Oniba, E. and Robertson, M. (2019), “Trialing a new scent-based repellent to mitigate elephant crop raiding around Murchison Falls National Park, Uganda”, *Pachyderm*, Vol. 60, pp. 123-125, doi: [10.21018/pac.2019](https://doi.org/10.21018/pac.2019).
- Phuong, H.T., Tan, N.Q., Nga, P.T.Q., Chau, D.T.M., Chan, N., Win, K. and Swe, K.N. (2024), “Climate change, livelihood resilience, and gender: an intersectional analysis of Vietnam’s forest-dependent communities”, *Environmental Development*, Vol. 52, 101072, doi: [10.1016/j.envdev.2024.101072](https://doi.org/10.1016/j.envdev.2024.101072).
- Pomarico, L.G. (2017), *Forest Conservation and Forced Relocation in Côte D’Ivoire*, The State of Environmental Migration, pp. 185-208.
- Proctor, C. (2024), “Subjective well-being (SWB)”, in *Encyclopedia of Quality of Life and Wellbeing Research*, Springer International Publishing, Cham, pp. 6952-6956, doi: [10.1007/978-3-031-17299-1_2905](https://doi.org/10.1007/978-3-031-17299-1_2905).
- Quandt, A. (2018), “Measuring livelihood resilience: the household livelihood resilience approach (HLRA)”, *World Development*, Vol. 107, pp. 253-263, doi: [10.1016/j.worlddev.2018.02.024](https://doi.org/10.1016/j.worlddev.2018.02.024).
- Rodriguez, N.D. (2021), “Consequences of conservation-induced displacement: a case study with Batwa participants in Southwest Uganda”, *Master’s thesis*, University of Colorado Colorado Springs.
- Rongna, A. and Sun, J. (2020), “Integration and sustainability of tourism and traditional livelihood: a rhythm analysis”, *Journal of Sustainable Tourism*, Vol. 28 No. 3, pp. 455-474, doi: [10.1080/09669582.2019.1681437](https://doi.org/10.1080/09669582.2019.1681437).
- Saifullah, M.K., Masud, M.M. and Kari, F.B. (2021), “Vulnerability context and well-being factors of Indigenous community development: a study of Peninsular Malaysia”, *Alternative: An*

-
- International Journal of Indigenous Peoples*, Vol. 17 No. 1, pp. 94-105, doi: [10.1177/1177180120983178](https://doi.org/10.1177/1177180120983178).
- Saunders, M.N. and Townsend, K. (2018), "Choosing participants", in *Sage Handbook of Qualitative Business and Management Research Methods*, pp. 480-494.
- Scoones, I. (1998), "Sustainable rural livelihoods: a framework for analysis", IDS Working Paper 72, Institute of Development Studies, doi: [10.2139/ssrn.1491224](https://doi.org/10.2139/ssrn.1491224).
- Sina, D., Chang-Richards, A.Y., Wilkinson, S. and Potangaroa, R. (2019), "A conceptual framework for measuring livelihood resilience: relocation experience from Aceh, Indonesia", *World Development*, Vol. 117, pp. 253-265, doi: [10.1016/j.worlddev.2018.12.026](https://doi.org/10.1016/j.worlddev.2018.12.026).
- Sisneros-Kidd, A.M., Monz, C., Hausner, V., Schmidt, J. and Clark, D. (2019), "Nature-based tourism, resource dependence, and resilience of Arctic communities: framing complex issues in a changing environment", *Journal of Sustainable Tourism*, Vol. 27 No. 8, pp. 1259-1276, doi: [10.1080/09669582.2019.1612905](https://doi.org/10.1080/09669582.2019.1612905).
- Small, L.A. (2007), "The sustainable rural livelihoods approach: a critical review", *Canadian Journal of Development Studies/Revue canadienne d'études du développement*, Vol. 28 No. 1, pp. 27-38, doi: [10.1080/02255189.2007.9669186](https://doi.org/10.1080/02255189.2007.9669186).
- Smith, M.K.S., Smit, I.P., Swemmer, L.K., Mokhatla, M.M., Freitag, S., Roux, D.J. and Dziba, L. (2021), "Sustainability of protected areas: vulnerabilities and opportunities as revealed by COVID in a national park management agency", *Biological Conservation*, Vol. 255, 108985, doi: [10.1016/j.biocon.2021.108985](https://doi.org/10.1016/j.biocon.2021.108985).
- Sok, S. and Yu, X. (2015), "Adaptation, resilience and sustainable livelihoods in the communities of the Lower Mekong Basin, Cambodia", *International Journal of Water Resources Development*, Vol. 31 No. 4, pp. 575-588, doi: [10.1080/07900627.2015.1012659](https://doi.org/10.1080/07900627.2015.1012659).
- Solberg, A.M. (2022), "Community perception of environmental change in Queen Elizabeth National Park, Uganda", *Master's thesis*, Kent State University.
- Stone, M.T., Stone, L.S. and Nyaupane, G.P. (2022), "Theorizing and contextualizing protected areas, tourism and community livelihoods linkages", *Journal of Sustainable Tourism*, Vol. 30 No. 11, pp. 2495-2509, doi: [10.1080/09669582.2021.2003371](https://doi.org/10.1080/09669582.2021.2003371).
- Tanujaya, B., Prahmana, R.C.I. and Mumu, J. (2022), "Likert scale in social sciences research: problems and difficulties", *FWU Journal of Social Sciences*, Vol. 16 No. 4, pp. 89-101, doi: [10.51709/19951272/Winter2022/7](https://doi.org/10.51709/19951272/Winter2022/7).
- Tsao, C.Y. and Ni, C.C. (2016), "Vulnerability, resilience, and the adaptive cycle in a crisis prone tourism community", *Tourism Geographies*, Vol. 18 No. 1, pp. 80-105, doi: [10.1080/14616688.2015.1116600](https://doi.org/10.1080/14616688.2015.1116600).
- UBOS (2023), "Statistical abstract", available at: <https://www.ubos.org/wp-content/uploads/publications/2023-Statistical-Abstract.pdf>
- Vedeld, P., Cavanagh, C., Petursson, J.G., Nakakaawa, C., Moll, R. and Sjaastad, E. (2016), "The political economy of conservation at Mount Elgon, Uganda: between local deprivation, regional sustainability, and global public goods", *Conservation and Society*, Vol. 14 No. 3, pp. 183-194, doi: [10.4103/0972-4923.194567](https://doi.org/10.4103/0972-4923.194567).
- Wilson, C. and Secker, J. (2015), "Validation of the social inclusion scale with students", *Social Inclusion*, Vol. 3 No. 4, pp. 52-62, doi: [10.17645/si.v3i4.189](https://doi.org/10.17645/si.v3i4.189).
- Wilson, G.A., Hu, Z. and Rahman, S. (2018), "Community resilience in rural China: the case of Hu Village, Sichuan province", *Journal of Rural Studies*, Vol. 60, pp. 130-140, doi: [10.1016/j.jrurstud.2018.03.016](https://doi.org/10.1016/j.jrurstud.2018.03.016).
- World Bank (2022), "World development report", available at: <https://www.worldbank.org/en/publication/wdr2021>.
- World Travel And Tourism Travel (2023), "Tourism economic impact report", available at: <https://wtc.org/research/economicimpact#:~:text=In%202023%2C%20the%20Travel%0%26%20Tourism,4.1%25%20below%20the%202019%20level>
- Yamane, T. (1973), *Statistics: An Introductory Analysis*, Harper & Row.

JHASS

Yu, P., Zhang, J., Wang, Y., Wang, C. and Zhang, H. (2020), "Can tourism development enhance livelihood capitals of rural households? Evidence from Huangshan National Park adjacent communities, China", *Science of the Total Environment*, Vol. 748, 141099, doi: [10.1016/j.scitotenv.2020.141099](https://doi.org/10.1016/j.scitotenv.2020.141099).

Zhang, F., Lv, Y. and Sarker, M.N.I. (2024), "Resilience and recovery: a systematic review of tourism governance strategies in disaster-affected regions", *International Journal of Disaster Risk Reduction*, Vol. 103, 104350, doi: [10.1016/j.ijdr.2024.104350](https://doi.org/10.1016/j.ijdr.2024.104350).

Corresponding author

Michelle Kiconco can be contacted at: mkiconco@mubs.ac.ug