

Research

Design and implementation of a photovoltaic system for health facilities in rural areas of Uganda

Afam Uzorka¹ · David Kibirige¹ · Mundu Muhamad Mustafa² · John Kelechi Ukagwu²

Received: 29 August 2024 / Accepted: 21 February 2025

Published online: 03 March 2025

© The Author(s) 2025 [OPEN](#)

Abstract

The persistent issue of unreliable electricity in rural Ugandan healthcare facilities significantly hinders the provision of essential medical services, affecting everything from diagnostic testing to emergency care. This study addresses the urgent need for dependable, renewable energy solutions by designing and implementing a photovoltaic (PV) system specifically tailored to meet the energy requirements of rural health centres. The primary aim of this research was to develop a cost-effective, portable solar power system that can provide continuous power for critical medical equipment, including portable ultrasound scanners, medical centrifuges, vaccine refrigerators, and other essential diagnostic and monitoring devices. The PV system comprises two 50 W monocrystalline solar panels, a buck-boost converter for voltage regulation, a 12 V, 25 Ah maintenance-free battery for energy storage, and a single-phase inverter capable of producing 1 kW of power with an integrated inverter driver system to handle three-phase load requirements. Experimental testing was conducted over a three-month period, during which the system operated from 8:55 AM to 5:00 PM, five days a week. Data on voltage, current, power, and efficiency were recorded, showing an average system efficiency of 92.46%, even under varying sunlight conditions. The high efficiency and portability of the PV system underscore its suitability for off-grid healthcare facilities, enabling reliable operation of life-saving equipment and improving the quality and continuity of care. Compared with existing systems in similar regions, this study's approach offers a portable, robust, and low-maintenance solution that directly addresses the challenges faced by rural healthcare facilities. The key contribution of this research is its practical, adaptable PV system model, which can be scaled and modified for use in other resource-limited settings. By providing a renewable and consistent energy source, this study advances the field of sustainable healthcare infrastructure and highlights the potential of PV technology to improve healthcare accessibility in underserved areas.

Article Highlights

- Energy storage in a 12 V battery allows continuous power, crucial for facilities without stable electricity.
- The design's 92.46% efficiency ensures steady power crucial for medical equipment, even with fluctuating sunlight.
- The system's lightweight, mobile design allows easy relocation for optimal solar charging, overcoming fixed-installation limits.

Keywords Photovoltaic system · Healthcare electrification · Rural areas · Uganda · Renewable energy · Solar panels · Energy access · Off-grid

✉ Afam Uzorka, afamuzorka@gmail.com | ¹Department of Physical Sciences, School of Natural and Applied Sciences, Kampala International University, Kampala, Uganda. ²Department of Electrical, Telecommunication and Computer Engineering, School of Engineering and Applied Sciences, Kampala International University, Kampala, Uganda.



1 Introduction

The efficient provision of healthcare services depends on having access to dependable energy [1–3], yet many rural areas in Uganda and other comparable regions experience ongoing difficulties in this area [4–6]. Power outages are frequently caused by unreliable grid infrastructure, which makes it difficult for medical facilities to run vital equipment and deliver necessary services [4, 7]. Renewable energy technologies, particularly solar photovoltaic (PV) systems, have surfaced as potentially effective ways to improve healthcare services in underprivileged and distant regions and close the energy access gap [8–10].

In healthcare institutions, an unstable electrical supply might have serious repercussions. Nearly 60% of medical institutions in Sub-Saharan Africa, including Uganda, do not have access to power at all, according to International Energy Agency [11]. Frequent blackouts make it difficult for healthcare practitioners to provide reliable and secure patient care, even for those who are grid-connected. According to research, up to 90% of rural healthcare facilities in Uganda lack dependable power sources [12]. This results in issues performing life-saving surgeries and procedures, improper storage of vaccines and medications that need to be refrigerated, and a decreased capacity to provide medical services at night. One of the main medical facilities in the country, the Mbarara Regional Referral Hospital in southwest Uganda, has been known to suffer from regular outages, which significantly impairs its ability to provide care for the local rural population [13].

To function properly, critical medical devices like oxygen concentrators, incubators, and diagnostic instruments all need steady electricity. Without these, medical personnel are unable to offer proper care, which in emergency situations may be fatal. Power outages raise death rates because they delay treatment and increase the risk of infections from improperly stored medical supplies [14]. Particularly worrisome are power outages in maternity and child health care. Without proper illumination, rural clinics frequently cannot safely deliver babies at night leading to increase maternal mortality and complications [15]. Furthermore, according to UNICEF statistics, inadequate cold-chain storage which is largely caused by a lack of dependable refrigeration, leads to the loss of around 50% of vaccine doses in rural regions [16]. These figures make it abundantly evident that these healthcare institutions urgently require sustainable and alternative energy sources that can supply power continuously.

Uganda's location near the equator makes solar energy an alluring and practical way to address the country's rural electricity shortage. With an average of 5.2 kWh/m² of solar energy received each day [17], photovoltaic (PV) systems are a perfect option for producing power in Uganda. PV systems provide a sustainable, low-maintenance, and economical solution to the issue of inconsistent power in rural regions by converting solar into electrical energy. PV systems offer a long-term, clean energy option that can drastically lower operating costs and environmental effect in comparison to fuel-powered generators, which are frequently employed in these locations but are costly and environmentally unsustainable.

Despite the favourable solar conditions and increasing global adoption of photovoltaic technologies, the deployment of solar energy systems in Uganda has been relatively modest [18]. Key barriers include limited technical expertise, high initial costs, insufficient awareness of the benefits of solar energy, and inadequate policy frameworks to support the adoption of PV systems [18]. However, recent government initiatives, coupled with international partnerships and falling prices of solar technology, have created an environment conducive to expanding PV deployment in the country [19].

The perspectives of photovoltaics in Uganda are promising but require more concerted efforts to realize their full potential. Integrating PV systems into rural healthcare facilities can serve as a model for sustainable energy solutions across sectors, fostering economic development, reducing reliance on fossil fuels, and addressing climate change concerns. This study not only underscores the feasibility of PV adoption in Uganda but also highlights its critical role in ensuring equitable access to quality healthcare services.

A number of case studies from Sub-Saharan African rural communities have demonstrated in recent years how solar power might enhance healthcare services. For instance, a study conducted in rural Ghana focused on deploying fixed solar installations for powering health clinics, achieving efficiencies ranging between 85 and 90% [20]. A 2020 project in neighboring Rwanda installed photovoltaic (PV) systems powered by solar energy in 500 healthcare facilities [21], significantly reducing power interruptions and enabling consistent operation of the facilities. Significant advancements in healthcare delivery were shown by the study, especially in the areas of emergency response, maternal care, and vaccine storage [21]. Similar outcomes have been noted in Kenya, where the installation of solar energy systems in rural areas and health institutions has improved their ability to offer the local people reliable, life-saving treatments [21, 22].

This study focused on the design and implementation of a PV system especially suited for health facilities in rural areas of Uganda. This system uses solar energy to generate a stable and sustainable electricity supply to support critical

medical functions such as patient care, treatment protocols, and diagnostics. The PV system provides a comprehensive approach to meeting the energy needs of healthcare facilities in resource-constrained areas through a technique that includes PV modules, power conversion components, energy storage solutions, and system monitoring methods. The implementation of renewable energy technology in healthcare environments protects patient health and well-being by increasing the resilience of medical facilities to power outages and the reliability of the electricity supply. Additionally, solar PV systems help with environmental sustainability [23, 24] and worldwide efforts to battle climate change by lowering reliance on fossil fuels and minimizing greenhouse gas emissions [25].

This research designed and implemented a PV system, emphasizing its potential to completely transform the provision of healthcare in rural Uganda and in comparable settings. This project contributes to the larger objectives of sustainable development, equal access to healthcare, and enhanced quality of life for marginalized communities by giving them access to clean, renewable energy. The project demonstrates the scalability and efficacy of the PV system through empirical testing, setting the foundation for future developments in off-grid healthcare electrification initiatives.

For areas experiencing energy poverty, incorporating solar photovoltaic technology into healthcare facilities offers a route forward for sustainable development and better health results. It also signifies a paradigm change in energy access and healthcare delivery. To address the nexus of healthcare inequalities and energy access, this study clarifies the transformative potential of renewable energy solutions. Its findings could impact global health and sustainable development policy, practice, and research.

1.1 Literature review

In Uganda, rural healthcare facilities rely heavily on dependable energy to provide essential services, yet many do not have a steady supply of power. According to data from Uganda's Ministry of Health, more than 90% of rural clinics have frequent power outages [13], which impair their capacity to keep vaccinations on hand, run necessary equipment, and deliver life-saving treatment in an emergency. Research on the use of PV in rural Ugandan medical facilities reveals notable advancements in these domains. For example, more than 100 clinics in sub-Saharan Africa, including Uganda, now have solar power systems thanks to the USAID-funded "Powering Health" project [19]. These solutions enhanced vaccine cold-chain management and allowed medical equipment to run continuously, lowering vaccine spoiling rates by over 30% in some regions [12].

Furthermore, a study conducted by Li et al. [26], offers insightful information about PV performance under different shading conditions, which is a prevalent problem in Uganda's rural areas because of the surrounding environment. With a focus on the effects of shading and masking on system efficiency, this work offers a validated multi-physics model for precisely forecasting electrical, thermal, and structural performance. Strong performance forecasts are necessary for dependable system design in rural Uganda, where shadowed conditions such as trees or nearby structures, can have a substantial impact on PV production.

Partial shadowing is a well-known problem in the literature because it impacts PV systems' power production, particularly for Building Integrated Photovoltaics (BIPVs), which are important in environments with limited resources. Zhu et al. [27] examine how shading affects photocurrent and series resistance and offer a straightforward mathematical model for forecasting power losses in partial shading. The study is pertinent to rural clinics in Uganda, where environmental conditions frequently cause PV panels to be partially shaded. This model is a useful tool for areas with frequent shading issues because it helps design PV systems with low power loss even under fluctuating shading conditions by comprehending the relationship between shaded cell area proportion and photocurrent output.

Flexible solar systems, like those investigated by Li et al. [28], provide flexibility and resilience in rural environments as opposed to fixed installations. Flexible textile envelope-integrated PVs, which are lightweight and appropriate for applications with structural load and space limits, are evaluated by the authors. Flexible PV systems can be both economically and environmentally sustainable, as shown by the carbon footprint and lifetime cost analysis (LCCA) [28]. This is particularly important for Uganda's rural healthcare facilities, where infrastructure and financing are sometimes scarce. For small health centers and mobile clinics that can use portable, lightweight power solutions, these adaptable PV systems offer a promising alternative.

PV systems have been used in sub-Saharan African and Asian nations to close the energy gap in rural healthcare. For instance, the "Solar for Health" campaign in Kenya installed PV systems in more than 100 rural healthcare institutions [21], guaranteeing dependable electricity for nighttime lighting and medical equipment. The effort highlighted the clear connection between dependable power and better healthcare results, reporting a 20% rise

in the number of patients receiving care following the installations [21]. As part of the National Solar Mission, PV systems have been installed in rural health institutions in India [29, 30]. According to a research by the Indian Council of Medical Research (ICMR), maternal health services were enhanced by PV-powered rural clinics, especially by enabling urgent medical care and deliveries at night. In certain regions, this project led to a 15% decrease in maternal mortality [30], proving the life-saving potential of PV systems in rural healthcare settings like Uganda.

Perovskite solar cells (PSCs), one of the emerging PV technologies, have the potential to improve the deployment of PV systems. Lightweight and incredibly effective, perovskite cells are ideal for places like Uganda where affordability and simplicity of installation are top concerns. Using a life cycle cost analysis approach, Li et al. [31], investigated the application of PSCs for building-integrated photovoltaics, noting difficulties because of PSCs' shorter lifespan. Despite the fact that PSCs need to be replaced frequently, rural areas find them appealing because of their high efficiency and inexpensive material prices. Over time, the sustainability of these systems might be improved by reducing the trash produced by PSC replacements by using the authors' recommended circular economy strategy [31].

Additionally, developments in organic and perovskite cells with graphene transparent electrodes are highlighted by Li, Monticelli, and Zanelli [32], providing environmentally friendly substitutes for conventional PV systems. These developments are ideal for low-income areas since they lessen dependency on limited resources and offer more ecologically responsible choices. Using PV systems with graphene electrodes could help Uganda meet global sustainability targets by lowering the environmental impact of electricity production.

PV systems must take the environment into account, particularly in developing nations where sustainability is a top priority. Ethylene Tetrafluoroethylene (ETFE) cushion-integrated PV systems are the subject of a life cycle assessment (LCA) and life cycle cost analysis (LCCA) by Li et al. [33]. When these systems are compared to traditional PV glazing skylights, the study finds that ETFE-integrated transparent solar cells (EC-TSCs) offer lightweight, cost-effective alternatives for building integration. Due to their longevity and low maintenance needs, these systems have the potential to be used in Ugandan rural clinics, while being primarily researched for commercial structures.

Research has demonstrated that flexible PV systems, such as Building Integrated Photovoltaics (BIPV) provide insightful information for rural environments [34]. Because flexible PV systems combined with textile envelopes have been shown to be successful in lowering lifespan costs and carbon footprints, they are especially appealing in Uganda, where infrastructural resources are scarce. Flexible PVs can power field clinics and mobile health units, whereas BIPV models which incorporate solar cells into building materials may be appropriate for more permanent constructions.

In addition, Habeeb et al. [35] conducted research that highlights the importance of independent photovoltaic systems (PV) in supplying stable electricity for medical devices and critical services in remote healthcare facilities. These technologies reduce the need for fossil fuels and increase the healthcare infrastructure's resistance to power outages by utilizing solar energy. Similarly, techno-economic comparison of standalone and hybrid photovoltaic systems for healthcare applications was carried out by Raghuwanshi & Arya [36], emphasizing the significance of cost-effectiveness and system optimization. Recent developments in monocrystalline silicon solar cells were examined by He et al. [37], who emphasized the cells' increased efficiency and improved low-light performance, which are especially important for healthcare facilities operating in resource-constrained areas. PV system integration in healthcare settings has shown measurable improvements in patient outcomes and healthcare delivery. The effects of solar-powered medical equipment on maternal and child health outcomes in rural Ghana were studied by Lambers et al. [38], and their findings improved patient satisfaction and service delivery. Similarly, research conducted in sub-Saharan Africa's rural health facilities by Moner-Girona et al. [12] and Ulsrud [39] showed that solar electricity improved healthcare access and quality.

PV systems can revolutionize healthcare delivery by offering dependable, clean power sources, as shown in case studies from nearby Kenya and as far away as India. Innovative PV systems and algorithms for forecasting performance under local environmental conditions, like partial masking and shading, are highlighted in the variety of papers examined. The design and deployment of PV systems that can solve particular issues in rural healthcare facilities will be guided by these findings, improving resilience, sustainability, and care quality in disadvantaged areas.

2 Methodology

2.1 System design and component selection

The PV system has been designed according to the block diagram shown in Fig. 1, which comprises the four main parts of the PV system, the PV module, the battery, the inverter, and the buck-boost converter, was used to develop the system. A small healthcare facility's energy needs could be satisfied by the system's 1000 W (1 kW) power handling capacity. A comprehensive list of the chosen components is given in Table 1, and it includes:

PV Module: Two monocrystalline solar panels were selected because of their exceptional endurance and efficiency, making them appropriate for locations with sporadic sunlight. Through the conversion of sunlight into direct current (DC), these panels provide electrical energy.

Buck-Boost Converter: To control the power levels between the PV Module and Battery, the system needs a Buck-Boost Converter. Depending on the amount of power required and the amount of sunlight present, this component modifies the voltage.

Battery: To store extra energy, two batteries with a 50 amp-hour and 12 V capacity were added. These batteries facilitate continuous operation by ensuring power availability during times of low sunshine.

Inverter: To transform the DC electricity from the solar panels and batteries into AC power, a 1000 W (1 kW) single-phase inverter was selected. To increase the adaptability of power output for various appliances, it is additionally connected to an Inverter Driver System with Display (IDSD) to transform single-phase power into three-phase power.

To ensure that the PV system could function dependably in rural areas, each component was chosen based on its environmental resistance and compatibility with the system's power output needs.

Table 1 shows the component lists used in the design of the PV system.

2.2 System configuration and assembly

After selecting components, the PV system was assembled following the design layout from Fig. 1:

PV Module Installation: The solar panels were installed in an aluminium box. The panels were connected in series to achieve the desired input voltage.

Buck-Boost Converter Integration: Before being stored in the batteries, the PV Module's output was connected to the Buck-Boost Converter to control voltage levels. This converter maintained steady output despite variations in sunshine by adjusting voltage levels according to system load and sunlight availability.

Battery Connection: To reach a total storage capacity that would allow the batteries to maintain electricity for lengthy periods of time, they were linked in parallel. Even in the event that one battery needs to be maintained, the system will always have a steady supply thanks to this parallel connection.

Inverter Setup: The inverter, which transforms DC electricity into AC power appropriate for operating home and medical appliances, was linked to the DC output from the batteries. By converting the output from single-phase to three-phase power, the inverter's IDSD offers a variety of power supply choices.

2.3 Efficiency measurement procedure

Efficiency (η) of the system at each time point was calculated using the following formula:

$$\text{Efficiency}(\%) = \left(\frac{\text{Output Power (W)}}{\text{Input Power (W)}} \right) \times 100$$

where:

- Output Power (P_{out}) = $V_{out} \times I_{out} \times \text{PowerFactor}_{out}$
- Input Power (P_{in}) = $V_{in} \times I_{in} \times \text{PowerFactor}_{in}$
- V_{in} is the voltage at the input side (voltage generated by the photovoltaic system).

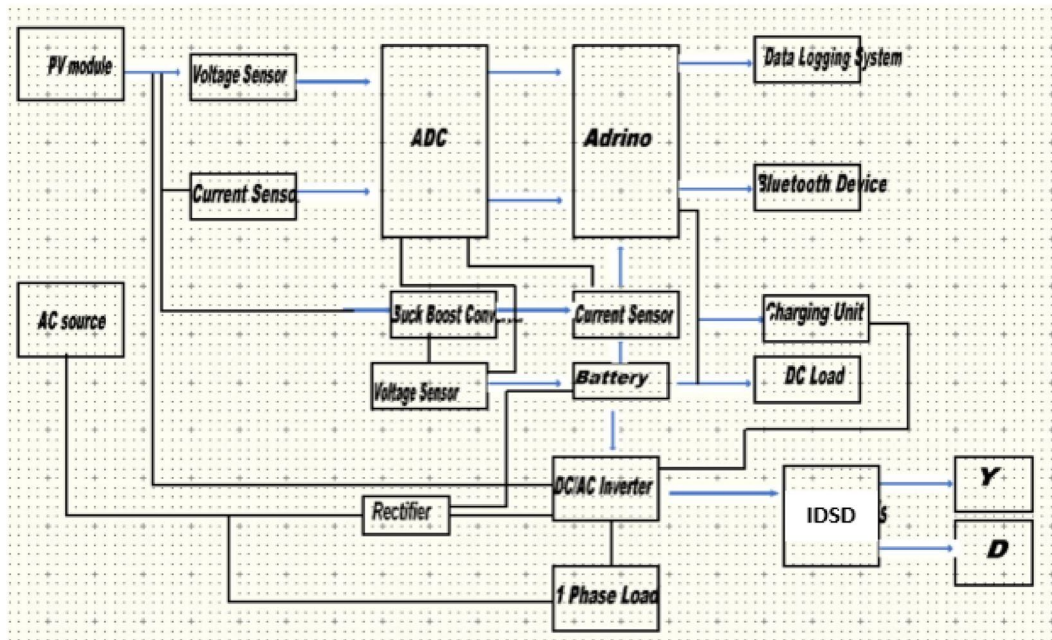

Fig. 1 Block diagram of the system

Where:

- I_{in} is the current at the input side.
- $Power\ factor_{in}$ is the power factor at the input side, which accounts for the phase difference between voltage and current at the input.
- V_{out} is the voltage at the load side (output voltage).
- I_{out} is the current at the load side.
- $Power\ factor_{out}$ is the power factor at the load side, accounting for the phase difference at the output.

The following steps were used to measure and calculate system efficiency:

Voltage Measurement: Voltage at both input (PV Module) and output (load) sides was measured using a voltmeter. This step was repeated at different times of the day to account for variations in sunlight intensity.

Current Measurement: An ammeter was used to measure the current at the input and output sides, recording variations in current according to power demand and sunshine availability.

Power Factor Measurement: To account for the phase difference between voltage and current, power factors were measured at both the input and output sides. To guarantee accuracy, power factor information was included in the power computations.

Data Logging: To obtain a complete dataset, measurements of voltage, current, and power factor were taken at different times. The system's efficiency over time was then determined by analyzing the data.

2.4 System testing and validation

The assembled system underwent a testing phase to verify that each component functioned as intended:

Load Testing: A collection of appliances, including lighting, refrigeration, and small medical gadgets, that are typical in rural healthcare settings were connected to the inverter. This made it possible to confirm the inverter's ability to provide steady electricity and adjust to various load demands.

Battery Performance Testing: Both full daylight and low light levels were used to assess the battery's storage and discharge rates. This confirmed that the batteries could efficiently store energy and supply backup power when required.

Table 1 Component list

S. No	Product	Model	Quantity
	Solar panel	50-Watt KYOCERA SM-85KSM mono-crystalline	02
	Battery	12 V maintenance free batteries	02
01	Microcontroller	PIC16F877A	02
02	Capacitor	0.1	04
		10 50 V (Electrolyte)	09
		470 50 V (Electrolyte)	08
		1000 16 V (Electrolyte)	01
03	Inductor	100 μ H	02
04	MOSFET	IRFZ44N	11
05	MOSFET Driver	IR2104	01
06	VOLTAGE regulator	LM7805	01
		LM7812	01
07	Inverting switching regulator	MC34063A	01
08	Diode	IN4917	07
09	Current sensor	ACS712ELCTR-30A-T	02
10	LED	Green	02
		Red	04
		Blue	01
11	LCD display	JHD204A	01
12	Transistors	T-MCU	03
13	Opto-coupler	PC817	01
14	Resistor	220.0 Ω	03
		1.0 k Ω	12
		3.3 k Ω	02
		10.0 k Ω	05
		100.0 k Ω	02
15	Fuse	T8AL250V	04
		25 A	01
16	Wire socket	–	03
17	USB port	–	02

Power Quality Verification: To make sure the AC power output was within permissible bounds for safe appliance use, its quality was checked. This involved checking that the inverter's output voltage and frequency were consistent.

Efficiency Analysis: To evaluate the system's performance and determine any modifications required to optimize power output, the efficiency were computed.

3 Results

Figure 2 shows the experimental set up and testing of the designed PV system.

The designed PV system consists of:

Solar Panels: Two 50 W solar panels were installed in a portable aluminium box.

LCD Screen: An LCD screen displays various system values like power, load, battery state of charge, current, and voltage for easy monitoring.

External Charging Unit: This unit charges electronic devices such as mobile phones, laptops, medical centrifuges, and portable ultrasound scanners.

Inverter Drive: Allows the system to handle three-phase loads by converting single-phase power to three-phase power.

Battery: A maintenance-free 12 V, 25 Ah battery stores excess energy.

Fig. 2 Experimental set up and testing of the designed PV system

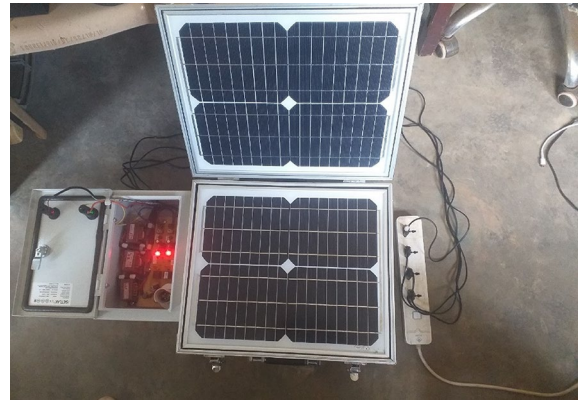

Oscilloscope: Used to visualize MOSFET pulses.

Digital Multimeter: Used to check buck-boost voltages.

Analog Meter: Helps compare values displayed on the LCD screen.

The PV system is designed as a portable aluminium box that can be easily moved around. It's flexible to charge from various locations and can then be brought back to the hospital for use. During testing, it was operated from 8:55 AM to 5:00 PM over five days a week for three months and showed an average efficiency of 92.46%. The experimental results in Table 2 provide insights into the photovoltaic (PV) system's performance, showcasing its high average efficiency of 92.46% across varying sunlight conditions. The system's efficiency remained relatively stable despite fluctuations in sunlight intensity throughout the day. One of the key features of this PV setup is its portability: housed in a lightweight aluminum box, it can be easily transported to areas with optimal sunlight, where it is charged and then returned to the hospital for use. This flexibility allows the system to bypass the limitations of fixed solar installations, which may face challenges due to shading or inconsistent sunlight at the hospital location.

Table 2 Experimental data

Sr.No	Time	Input				Load				Efficiency (%)
		Voltage (V)	Current (A)	Power factor	Power (W)	Voltage (V)	Current (A)	Power factor	Power (W)	
1	08.55AM	14.40	1.58	0.99	22.52	12.60	1.76	0.99	21.95	97.47
2	09.25AM	13.91	2.89	0.99	39.80	13.44	2.83	0.89	33.85	85.05
3	09.55AM	14.24	1.99	0.98	27.77	13.03	1.74	0.88	19.95	71.84
4	10.25AM	13.63	1.99	0.95	25.77	13.31	1.92	0.98	25.04	97.17
5	10.55AM	14.02	2.45	0.98	33.66	13.62	2.51	0.97	33.16	98.51
6	11.25AM	14.10	2.89	0.92	37.49	13.93	2.61	0.93	33.81	90.18
7	11.55AM	14.22	0.26	0.99	03.66	12.22	0.25	0.90	02.75	75.14
8	12.25PM	14.21	2.78	0.99	39.12	13.94	2.82	0.99	38.92	99.49
9	12.55PM	13.84	1.92	0.89	23.65	13.53	1.95	0.89	23.48	99.28
10	01.22PM	14.02	2.89	0.88	35.66	14.11	2.53	0.91	32.49	91.11
11	01.52PM	14.31	1.77	0.99	25.08	13.52	1.87	0.97	24.52	97.77
12	02.10PM	13.92	0.47	0.89	05.82	12.81	0.47	0.87	05.23	89.86
13	02.30PM	14.00	1.79	0.97	24.31	13.50	1.80	0.91	22.11	90.95
14	02.55PM	14.53	2.64	0.94	36.06	14.14	2.68	0.92	34.86	96.67
15	03.25PM	13.42	0.51	0.93	06.37	12.93	0.52	0.88	05.92	92.94
16	04.00PM	13.44	0.47	0.99	06.25	12.92	0.47	0.95	05.77	92.32
17	04.25PM	13.32	0.45	1.00	05.99	12.91	0.46	0.96	05.70	95.16
18	04.55PM	13.31	0.55	0.98	07.17	12.92	0.55	0.99	07.03	98.05
19	05.00PM	13.31	0.55	0.89	06.52	12.81	0.47	0.95	05.72	97.73
Average										92.46

Higher efficiency readings between 10:00 AM and 2:00 PM are primarily due to stronger solar irradiance, resulting in higher input power and an optimized output, with efficiencies frequently approaching 98–99%. During early morning and late afternoon, efficiencies slightly dropped, ranging between 70 and 90%, which aligns with reduced sunlight levels and subsequently lower power output.

To monitor and verify real-time data, such as voltage, current, and power factors, as well as to validate steady output levels, the LCD screen, external charging unit, inverter drive, and oscilloscope were all essential. Accuracy was ensured by the digital and analog meters, which helped confirm consistency between the data that was shown and the measurements taken in real time. The system's usefulness for rural environments was demonstrated by its portable aluminum box design, which made it possible to readily move the setup to other locations or adjust it to optimize sunshine exposure.

4 Discussion

The difficulty of unstable electricity supply in rural areas of Uganda can be addressed with a viable solution: the design and implementation of photovoltaic (PV) systems for health institutions in rural Uganda. The study's technique consists of four primary parts that work together to create a portable and effective system: PV modules, batteries, a buck-boost converter, and an inverter. The PV module's use of monocrystalline solar panels guarantees the best possible energy generation from sunshine, adding to the system's dependability and sustainability. This decision is consistent with earlier studies showing that monocrystalline solar panels outperform other solar panel types in low-light circumstances and have higher efficiency [37].

One of the distinguishing features of this work is the integration of key components that enhance both functionality and usability. For instance, the system's real-time monitoring capabilities, facilitated by the LCD screen, ensure that healthcare personnel can easily track energy availability and system performance without requiring advanced technical expertise. Furthermore, the inclusion of an external charging unit, an inverter drive for handling three-phase loads, and a maintenance-free battery demonstrates a comprehensive design approach tailored to the specific needs of rural health facilities. These design elements underscore the originality of this study, as similar systems often lack the modularity and portability critical for applications in remote areas.

By including a buck-boost converter, power levels can be changed as needed to maximize energy efficiency and improve the system's capacity to adapt to changing environmental circumstances. This part is essential to preserving consistent power output and optimizing the PV system's efficiency. The energy storage capabilities of the batteries, which have a 50 A-hour and 12-V capacity, allow continuous power supply. Wang et al. [10] have highlighted in similar research the significance of incorporating energy storage technologies into photovoltaic systems for a continuous power supply, especially in off-grid or unstable grid conditions. An essential component in transforming DC power from solar panels and batteries into AC power that health facilities appliances can use is the inverter. The integration of a 1000-W (1 kW) single-phase inverter and an Inverter Driver System with a Display (IDSD) for three-phase power conversion expands the system's adaptability and suitability for a variety of medical devices and appliances.

The PV system is designed in the form of aluminium box which makes it portable, emphasizes its appropriateness for use in remote healthcare environments. This function ensures that there is always electricity available for vital medical procedures by allowing medical staff to take the system to various locations for charging before returning it to the hospital. This flexibility mitigates challenges such as shading or suboptimal placements that are commonly encountered in static PV setups.

The high average efficiency of 92.46% underscores the PV system's suitability for powering rural healthcare facilities, aligning with findings from similar studies in sub-Saharan Africa and other developing regions. The consistency of the system's output, even during periods of moderate to low sunlight, showcases its reliability, a crucial factor for off-grid health facilities that depend on consistent power for critical equipment like medical centrifuges, ultrasound scanners, and battery-powered lights.

This study builds upon and distinguishes itself from similar PV system implementations reported in other African countries with comparable meteorological conditions, such as Ghana and Kenya. For instance, a study conducted in rural Ghana focused on deploying fixed solar installations for powering health clinics, achieving efficiencies ranging between 85 and 90% [20]. While effective, the lack of portability limited their adaptability to varying sunlight conditions and different clinic locations. Similarly, a project in Kenya demonstrated the use of PV systems for rural electrification, with a primary focus on household energy needs [22]. These systems, however, often lacked the specific design features required for healthcare applications, such as the ability to power critical medical devices like centrifuges and portable

ultrasound scanners. Moreover, the incorporation of an inverter drive for handling three-phase loads sets this work apart, as it extends the range of equipment that can be powered, an aspect often overlooked in similar studies.

Studies like Li et al. [26], which examined the performance of Building Integrated Photovoltaic (BIPV) systems under shading and masking conditions, emphasized the importance of accounting for shading in performance predictions. In contrast, the present study's approach involved testing the system across varying sunlight intensities without explicit shading, revealing high efficiency in non-shaded settings. The adaptability of the buck-boost converter to voltage changes may explain the superior efficiency rates observed in this system compared to those impacted by shading as discussed by Li et al. [26] and Zhu et al. [27].

In the study of Li et al. [28], flexible and sustainable energy solutions were investigated through carbon footprint evaluations of Textile Envelope Integrated Flexible Photovoltaic (TE-FPV) systems intended as sunshades in educational buildings in Europe. Despite being less complex and technologically sophisticated, the PV system in our study reached similar levels of efficiency, making it a more practical and financially viable choice for Ugandan rural healthcare facilities.

In their study of the environmental sustainability of ETFE cushion-integrated solar cells for building applications, Li et al. [33] relied heavily on life cycle cost analysis (LCCA) and life cycle assessment (LCA). The 12 V, 25 Ah maintenance-free battery employed in our study guarantees little environmental impact due to its longer operating lifespan, which minimizes replacement frequency, even though life cycle assessment (LCA) was not carried out in this study. Compared to more complicated systems made for urban structures, this PV system's simple, low-maintenance design makes it an economical and sustainable option.

5 Conclusion

A major step toward resolving the issues of inconsistent energy availability in marginalized communities has been taken with the design and installation of a photovoltaic (PV) system specifically designed for health facilities in rural Uganda. A portable and effective energy solution has been made possible by a thorough process that includes PV modules, batteries, a buck-boost converter, and an inverter. The system's usefulness and dependability are demonstrated by the experimental setup's findings, which show an amazing average efficiency of 92.46%. This performance highlights the system's ability to offer reliable and sustainable electricity for vital medical procedures, even in isolated locations with inadequate infrastructure.

Through the integration of efficient power conversion mechanisms, energy storage capabilities, and monocrystalline solar panels, the PV system provides a resilient solution that is customized to meet the unique requirements of healthcare facilities operating in resource-constrained areas. Its portability adds to its versatility by allowing medical professionals to use it wherever necessary and guaranteeing that vital medical services and equipment will always have access to energy. The system's performance parameters are validated through comparative analysis with extant literature, thereby placing it as a competitive alternative for off-grid healthcare electrification programs.

In conclusion, the design and implementation of the PV system demonstrate how renewable energy technologies can completely transform the way that healthcare is provided in underserved areas. Through the use of solar energy, this project not only solves current issues with electricity access but also advances more general objectives of resilience, sustainable development, and enhanced quality of life for marginalized communities in rural Uganda.

5.1 Recommendations

The following suggestions are put forth to improve and expand the use of solar energy for rural healthcare facilities in light of the PV system's successful design and performance in this study:

1. Customization and Scaling to Meet Various Healthcare Requirements

Similar systems ought to be tailored and expanded to accommodate certain healthcare requirements, considering the system's proven effectiveness in supporting small medical devices. For establishments with higher energy requirements, including those needing refrigeration for vaccinations or more extensive lighting, larger or multi-panel configurations could be created. Resilience and healthcare delivery will be enhanced by customizing the system's inverter characteristics and battery capacity to support a variety of devices.

2. Incorporating Real-Time Monitoring Systems

Healthcare professionals and technical staff might monitor performance parameters including energy production, battery health, and system efficiency in real-time by incorporating sophisticated monitoring and remote tracking features, such as cloud-connected data loggers. In remote locations where prompt repairs are difficult, this capability would help predict maintenance requirements, extend battery life, and optimize power utilization.

Author contributions A.U., D.K. contributed to the study conception. A.U., D.K., M.M.M, J.K.U. contributed to the study, design, and all aspect of the manuscript. The first draft of the manuscript was written by A.U., D.K., M.M.M, J.K.U. and A.U., D.K., M.M.M, and J.K.U. read and approved the final manuscript.

Data availability All data used will be made available on request.

Declarations

Competing interests The authors declare no competing interests.

Open Access This article is licensed under a Creative Commons Attribution-NonCommercial-NoDerivatives 4.0 International License, which permits any non-commercial use, sharing, distribution and reproduction in any medium or format, as long as you give appropriate credit to the original author(s) and the source, provide a link to the Creative Commons licence, and indicate if you modified the licensed material. You do not have permission under this licence to share adapted material derived from this article or parts of it. The images or other third party material in this article are included in the article's Creative Commons licence, unless indicated otherwise in a credit line to the material. If material is not included in the article's Creative Commons licence and your intended use is not permitted by statutory regulation or exceeds the permitted use, you will need to obtain permission directly from the copyright holder. To view a copy of this licence, visit <http://creativecommons.org/licenses/by-nc-nd/4.0/>.

References

1. Lee CC, Yuan Z. Impact of energy poverty on public health: a non-linear study from an international perspective. *World Dev.* 2024;174:106444.
2. Kibirige D, Uzorka A, Mustafa MM, Ukagwu KJ. Design and implementation of a charge controller for solar PV systems for emergency situations in health facilities in rural areas of Uganda. *Eng Sci Technol.* 2024. <https://doi.org/10.37256/est.5220244153>.
3. Dion H, Evans M. Strategic frameworks for sustainability and corporate governance in healthcare facilities; approaches to energy-efficient hospital management. *Benchmarking Int J.* 2024;31(2):353–90. <https://doi.org/10.1108/BIJ-04-2022-0219>.
4. Muhamad MM, Kibirige D, Uzorka A, John UK. Design and simulation of an inverter drive system with a display for a renewable energy system in the rural isolated communities of Uganda. *J Power Energy Eng.* 2022;10(12):1–14.
5. Di Pietro L, Piaggio D, Oronti I, Maccaro A, Houessouvo RC, Medenou D, Ahluwalia A. A framework for assessing healthcare facilities in low-resource settings: field studies in Benin and Uganda. *J Med Biol Eng.* 2020;40:526–34. <https://doi.org/10.1007/s40846-020-00546-3>.
6. Javadi D, Ssempebwa J, Isunju JB, Yevo L, Amu A, Nabiwemba E, Severi L. Implementation research on sustainable electrification of rural primary care facilities in Ghana and Uganda. *Health Policy Plan.* 2020;35(Supplement_2):124–36.
7. Kibirige D, Uzorka A, John UK, Muhamad MM. Electrical and thermal performance analysis of a 1000W monocrystalline solar PV power generator in Eastern Uganda. *Int J Sci Res Publ (IJSRP).* 2022. <https://doi.org/10.29322/IJSRP.12.10.2022.p13042>.
8. Ukagwu KJ, Kibirige D, Uzorka A, Mustafa MM. Modelling and simulation of a renewable energy system for remote isolated health facilities in Uganda using Simulink. *Am Acad Sci Res J Eng Technol Sci.* 2022;90(1):277–99.
9. Al-Rawi OF, Bicer Y, Al-Ghamdi SG. Sustainable solutions for healthcare facilities: examining the viability of solar energy systems. *Front Energy Res.* 2023;11:1220293.
10. Wang W, Yuan B, Sun Q, Wennersten R. Application of energy storage in integrated energy systems—a solution to fluctuation and uncertainty of renewable energy. *J Energy Storage.* 2022;52: 104812.
11. Ouedraogo I, Jiya AN, Dianda I. On the effects of access to electricity on health capital accumulation in Sub-Saharan Africa. *J Energy Develop.* 2022;48(1/2):83–108.
12. Moner-Girona M, Kakoulaki G, Falchetta G, Weiss DJ, Taylor N. Achieving universal electrification of rural healthcare facilities in sub-Saharan Africa with decentralized renewable energy technologies. *Joule.* 2021;5(10):2687–714.
13. Nabulo H, Gottfredsdottir H, Joseph N, Kaye DK. Experiences of referral with an obstetric emergency: voices of women admitted at Mbarara regional referral hospital, South Western Uganda. *BMC Pregnancy Childbirth.* 2023;23(1):498. <https://doi.org/10.1186/s12884-023-05795-z>.
14. Irwin BR, Hoxha K, Grépin KA. Conceptualising the effect of access to electricity on health in low-and middle-income countries: a systematic review. *Glob Public Health.* 2020;15(3):452–73.
15. Casey JA, Fukurai M, Hernández D, Balsari S, Kiang MV. Power outages and community health: a narrative review. *Curr Environ Health Rep.* 2020;7:371–83. <https://doi.org/10.1007/s40572-020-00295-0>.
16. Gedi EM, Evaluation of the storage and cold chain management of vaccines in the primary health facilities in Arusha City, Northern Tanzania (Doctoral dissertation, university of nairobi), 2022.
17. Gager E, Energy access for socio-economic development: impact and potential of decentralized electricity generation in rural Uganda (Doctoral dissertation), 2012.

18. Mundu MM Modelling and navigation of solar electric power potential and generation in the four regions of Uganda (Doctoral dissertation, Kampala International University, College of Environmental Science and management), 2021.
19. Allela T. A 2020 desk review of power Africa. *J Int Dev.* 2022;34(2):334–48.
20. Javadi D, Ssempebwa J, Isunju JB, Yevo L, Amu A, Nabiwemba E, Severi L. Implementation research on sustainable electrification of rural primary care facilities in Ghana and Uganda. *Health Policy Plan.* 2020;35(Supplement_2):ii124–36. <https://doi.org/10.1093/heapol/czaa077>.
21. Imasiku K., Saunyama L. Analysis of renewable energy deployment and investment for rural health facility electrification: a case study of Kenya, Ghana, and Rwanda. In: *Qeios* <https://doi.org/10.32388/PZUCFP>
22. Hansen JM, Xydis GA. Rural electrification in Kenya: a useful case for remote areas in sub-Saharan Africa. *Energy Eff.* 2020;13(2):257–72. <https://doi.org/10.1007/s12053-018-9756-z>.
23. Ali S, Yan Q, Dilanchiev A, Irfan M, Fahad S. Modeling the economic viability and performance of solar home systems: a roadmap towards clean energy for environmental sustainability. *Environ Sci Pollut Res.* 2023;30(11):30612–31.
24. Hamidinasab B, Javadikia H, Hosseini-Fashami F, Kouchaki-Penchah H, Nabavi-Pelesaraei A. Illuminating sustainability: a comprehensive review of the environmental life cycle and exergetic impacts of solar systems on the agri-food sector. *Sol Energy.* 2023;262: 111830.
25. Al-Ismaïl FS, Alam MS, Shafiqullah M, Hossain MI, Rahman SM. Impacts of renewable energy generation on greenhouse gas emissions in Saudi Arabia: a comprehensive review. *Sustainability.* 2023;15(6):5069.
26. Li Q, Zhu L, Sun Y, Lu L, Yang Y. Performance prediction of building integrated photovoltaics under no-shading, shading and masking conditions using a multi-physics model. *Energy.* 2020;213: 118795. <https://doi.org/10.1016/j.energy.2020.118795>.
27. Zhu L, Li Q, Chen M, Cao K, Sun Y. A simplified mathematical model for power output predicting of building integrated photovoltaic under partial shading conditions. *Energy Convers Manage.* 2019;180:831–43. <https://doi.org/10.1016/j.enconman.2018.11.036>.
28. Li Q, Monticelli C, Kutlu A, Zanelli A. Feasibility of textile envelope integrated flexible photovoltaic in Europe: carbon footprint assessment and life cycle cost analysis. *J Clean Prod.* 2023;430: 139716. <https://doi.org/10.1016/j.jclepro.2023.139716>.
29. Joshi G, Yenneti K. Community solar energy initiatives in India: a pathway for addressing energy poverty and sustainability? *Energy and Buildings.* 2020;210: 109736. <https://doi.org/10.1016/j.enbuild.2019.109736>.
30. Sharma L., Singh J., Dhiman R., Nunez DRV., Ba AE., Joshi KJ., Seidel M. Advancing solar energy for primary healthcare in developing nations: addressing current challenges and enabling progress through UNICEF and collaborative partnerships. *Cureus.* 2024; 16(1).
31. Li Q, Chen Z, Li X, Brancart S, Overend M. Vertical perovskite solar cell envelope for the circular economy: a case study using life cycle cost analysis in Europe. *J Clean Prod.* 2024;467: 143017. <https://doi.org/10.1016/j.jclepro.2024.143017>.
32. Li Q, Monticelli C, Zanelli A. Life cycle assessment of organic solar cells and perovskite solar cells with graphene transparent electrodes. *Renewable Energy.* 2022;195:906–17. <https://doi.org/10.1016/j.renene.2022.06.075>.
33. Li Q, Li T, Kutlu A, Zanelli A. Life cycle cost analysis and life cycle assessment of ETFE cushion integrated transparent organic/perovskite solar cells: comparison with PV glazing skylight. *J Build Eng.* 2024;87: 109140. <https://doi.org/10.1016/j.jobbe.2024.109140>.
34. Li Q, Monticelli C, Kutlu A, Zanelli A. Environmental performance analysis of textile envelope integrated flexible photovoltaic using life cycle assessment approach. *J Build Eng.* 2024;89: 109348. <https://doi.org/10.1016/j.jobbe.2024.109348>.
35. Habeeb A, Hizam H, Othman ML, Abdul Wahab NI, Rohouma W. Design simulation and performance evaluation of a standalone photovoltaic system for a health care facility in Malaysia. *Energies.* 2023;16(14):5342.
36. Raghuvanshi SS, Arya R. Design and economic analysis of a stand-alone hybrid photovoltaic energy system for remote healthcare centre. *Int J Sustain Eng.* 2020;13(5):360–72.
37. He X, Chen J, Ren X, Zhang L, Liu Y, Feng J, Liu S. 40.1% record low light solar cell efficiency by holistic trap passivation using micrometer thick perovskite film. *Adv Mater.* 2021;33(27):2100770.
38. Lammers K, Linke A, Andrade A, Cader C. Increasing electricity access for health facilities in Ghana through solar powered mini-grids—a GIS-based energy system modelling approach. *Environ Res Infrastruc Sustain.* 2024;4(2):025004.
39. Ulsrud K. Access to electricity for all and the role of decentralized solar power in sub-Saharan Africa. *Norsk Geografisk Tidsskrift-Norwegian J Geogr.* 2020;74(1):54–63.

Publisher's Note Springer Nature remains neutral with regard to jurisdictional claims in published maps and institutional affiliations.